

Parts Collection

2012-2013

Guitar, Bass & String Instruments PARTS



ブラッククロームメッキ再開

当社では、2006年のRoHS指令の施行に準じ、規制対象物質の1つである六価クロームを含有するメッキ（ブラッククローム）を施した製品の生産を自粛してまいりました。その理由として、施行当初よりその検出方法をめぐり情報が交錯し、絶対的な基準値が定まらなかった事があげられます。

しかし、六価クロームの検出方法が「煮沸による溶出検出値」の評価との見解に至り、当社製品においてはその基準値を遥かに下回る六価クローム数値が確認されております。よって「ブラッククローム製品」の製造を再開いたします。



B: ブラッククローム



CK2: コスモブラック2

Technical Innovation



LUBRI-COAT™

Lubri-Coat* が作り出す糸巻きの未来型。

ウォームギアにおいて Lubri-Coat(固体潤滑層)を施す事で、ウォームとギアホイルのコンタクトをよりタイトに設定する事が可能となり、チューニング時のバックラッシュを最小限にします。さらに GOTOH オリジナルの耐劣化高潤滑型オイルとの相乗効果で、精度や耐久性を長期間維持することができます。

*1. Lubri-Coat PAT. (PCT)

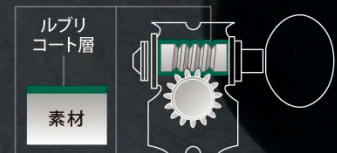

LUBRI-PLATE™

Lubri-Plate*1 が作り出すミクロの精度とフィーリング。

ウォームとホイールにテフロンを配合した Lubri-Plate(潤滑複合メッキ層)を施す事で、滑らかなみ合いと耐久性を高めます。更に G.S.P.*2 の採用で、究極のフィーリングを体感できます。

*1. Lubri-Plate PAT. (PCT)

*2. G.S.P GOTOH オリジナル非油性潤滑剤

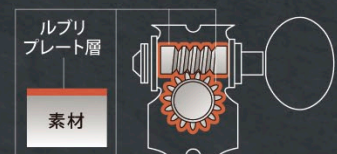

ROCK-SOLID™ STRING POST

アーミングやチョーキング時にも軸がぶれない理想のポスト。

ギア、巻軸、本体のアッセンブリーから不要なガタつきを排除。主要部に特殊弾性部品を採用した事により、弦の振動を最大限に楽器へ伝えます。アーミングやチョーキング時の効果が絶大であるのはもちろんの事、糸巻きの完成度を極限まで高める先端技術がここにもあります。

* Rock-solid String post PAT. (PCT)





汚れや水を寄せ付けず、
独自の色合いを醸し出す
究極のフィニッシュ。

X-Finishとは Lubri-Plate を外装メッキとして採用したフィニッシュです。超撥水性と超潤滑性を融合し、独特の色合いを持った最高級フィニッシュです。従来のメッキでは汗、潤滑油に付着した埃や汚れが時間の経過とともに酸化してしまい、錆・腐食等の原因となっていました。X-Finish は水や埃を寄せ付けず、錆や汚れを防ぎ各回転部の保護をします。その為、糸巻きとしての機能や耐久性も大幅に向上します。尚、使用状況によりカラーは変化しますが性能に問題はありません。

X-Finish と Lubri-Plate を施した糸巻きは、今までにないチューニングレスポンスと高耐久性を実現します。

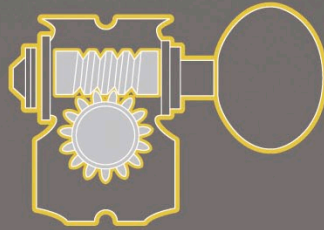

X-FINISH を素材表面に施します。

■ **Guitar Machine Heads**

SG-510Series ・ SE-510Series ・ SE-700Series ・ SD-510Series

■ **Classic Guitar Machine Heads**

35G510AM ・ 35G510MF ・ 35G510S

■ **Bass Guitar Machine Heads**

RES-O-LITE Series
GB350 ・ GB640 ・ GBR640 ・ GB528 ・ GB528S

■ **Tremolo Units**

EV510T ・ EV510TS

■ **Guitar Bridges**

510FA ・ 510FB ・ 510UB

■ **Bass Bridges**

J510SJ/BO ・ 404SJ/BO ・ 303SJ/BO

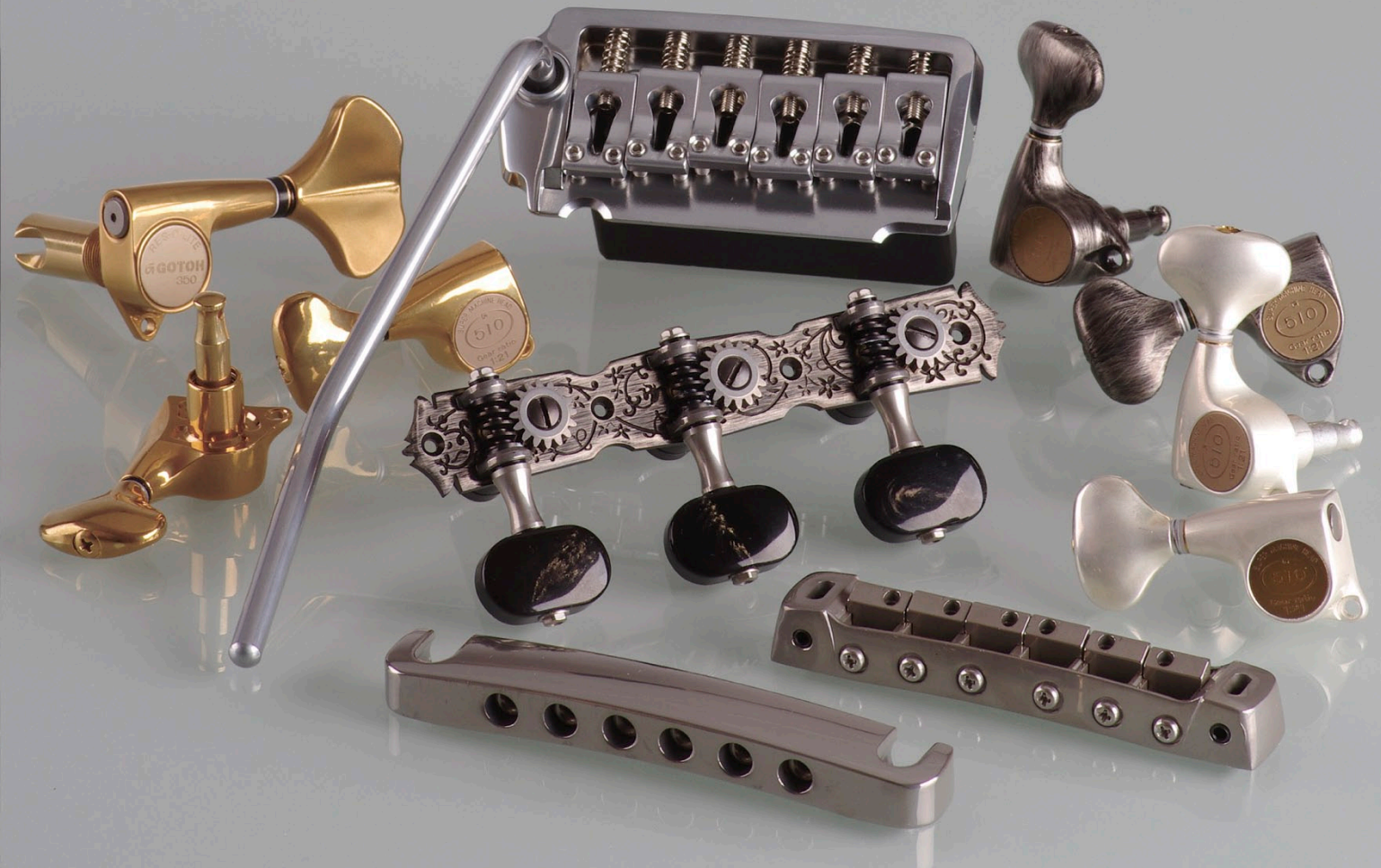



■ H.A.P. 可動イメージ

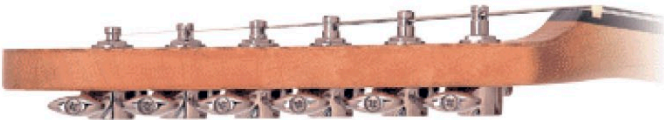

H.A.P.® [Height Adjustable Post] W. PAT.

軸の高さが設定できるH.A.P.は、ナットにかかる弦プレッシャーを各弦ごとに適正化でき、理想の弦振動を得られます。弦のサスティーン、タッチテンションをコントロールする事で、奏者に合ったコンディションに設定できます。H.A.P.は、スタンダード軸に対し、軸を低くする方向に多く可動するように設定されている為、ヘッドアングルの少ないストレートタイプのネックに使用すると有効です。

H.A.P.®-A W. PAT.

H.A.P.-Aは、軸可動量がスタンダード軸に対し高くする方向に多く可動するように設定されています。アングルタイプのネック（アコースティックギター等）に使用するとタッチテンションが弱くなり、弦を押さえるのが楽になると同時にサスティーンも向上します。

H.A.P.®-M PAT.

H.A.P.システムとマグナムロックを合わせ持つシステムです。

既に定評のあるH.A.P.Mですが、基本機能はそのままに、1～3弦の弦通し穴を適切な径（φ1.2）にした事で、より確実な弦ロックを実現しました。ヘッドアングルの少ないタイプのネックでは、各弦のポストを低くしてストリングアングルを保つ事で、ストリングリテイナーを排除する事ができます。

アミング時、チューニングに悪影響を及ぼす弦とストリングリテイナーとの摩擦抵抗が無くなり、チューニングの安定性が向上します。



H.A.P. 軸



H.A.P.-A 軸



H.A.P.-M 軸

Contents

News	1
Lubri-Coat / Lubri-Plate / Rock-Solid	
X-Finish	2
String Post Description	3 - 4
H.A.P / H.A.P-A / H.A.P-M	
Magnum Lock / Double Speed Lock	
Guitar Machine Heads	5 - 8
SG510 Series / SG Series	
Guitar Machine Heads	9 - 10
SE510 Series / SE Series	
Guitar Machine Heads	11 - 12
SD510 Series / SD Series	
STEALTH-KEY	13 - 14
ST31 Series	
Classic Guitar Machine Heads	15 - 17
35G510 Series / 35G Series	
Mandarin Machine Heads	18
Bass Machine Heads	19 - 21
RES-O-LITE Series / Regular Series	
Ukulele Pegs	22
Tremolo Units	23 - 24
510 Series	
Tremolo Units & Lock Nuts	25
Guitar Bridges	26
510 Series	
Guitar Bridges & Tailpieces	27 - 28
Bass Bridges	29 - 30
Multi-Tonal Series	
Bass Bridges	31
510 Series / Regular Series	
Art Collection	32
Special Parts	
Arms	33
Saddle sets / Side Adjuster	34
Strap pin / Free Lock / String Bushing	35
Jack Cover / Neck Joint Plate	
Control Panel / Tension Bar / Dome Knob	36
String Retainer	
Battery Box / Wrench Holder / Spring Holder	37
Spring / Power Spring	
Wilkinson by GOTOH	38
Tremolo & Bridge	



スタンダード軸

GOTOH マシンヘッド、SG シリーズおよび SD シリーズにはスタンダード軸、マグナムロック (MG) 軸、軸の高さの調整ができる H.A.P / H.A.P.A / H.A.P.M の軸バリエーションがあります。

更に軸の不要なガタつきをなくした「Rock-Solid スtringポスト」も設定され (一部機種を除く)、チューニング・アーミング時のチューニングの狂いを最小限にすることができます。GOTOH の先進性、開発力、技術力は、世界のカスタムショップを中心に絶大な信頼を得ています。

* 詳しい取り扱い方法に関しましては当社HPの動画マニュアルをご覧ください。

<http://www.g-gotoh.com>



MG [MAGNUM LOCK®] PAT.

GOTOH マグナムロックは弦のチューニングテンションを利用してロックする機構です。一般的なロック式ペグと違い必要以上に弦を潰す事が無い為、過剰なロックによる弦切れもありません。トレモロ装置を搭載した楽器においてアームダウン時、軸に巻かれた弦の緩みで生じるチューニングの狂いを最小限にします。

1 ~ 3 弦の弦通し穴を適切な径 (φ1.2) にした新マグナムロックは、従来品よりも確実な弦ロックを実現し、チューニング安定性が更に向上しました。



マグナムロック
1~3弦用 穴径φ1.2

マグナムロック
4~6弦用 穴径φ1.8



マグナムロック軸



DSL [DOUBLE SPEED MAGNUM LOCK®] PAT. [DOUBLE SPEED H.A.P.-MAGNUM LOCK®] PAT.

SG510 シリーズ・SD510 シリーズの MG と H.A.P.M が進化しました。

ルックス・機能はそのままにロックナットの可動スピードを倍速化。従来品の MG に対し半分の時間で弦ロックが可能になりました。

※SG510 シリーズ&SD510 シリーズの MG および H.A.P.M は、全機種ダブルスピードロック搭載となります。

■ 倍速可動の仕組み



DSL の
キャップを外した状態



入口

入口

分かりやすくするため
軸の先端をカットしています。

ネジの入り口が2ヶ所あり螺旋が2条になっている。

ご使用に際しては、取扱説明書に基づき正しくご使用ください。

Guitar ▶	L3+R3	L6 for Right Hand	R6 for Left Hand
Bass ▶	L2+R2	L4 for Right Hand	R4 for Left Hand

SG510 Series

Electric and Acoustic Guitar Machine Heads

世界が認めたスーパーチューナー

世界初のギアレシオ 1 : 21 を採用。数々の先端技術を標準装備し、全てに妥協することなく更なる改良を続け進化していく SG510 シリーズ。ギヤーの噛み合い精度の向上や操作時の絶妙な感触など、その総合性能が世界中の多くのプレーヤーから No.1 マシンヘッドとして高い信頼と評価を得ています。

SGS510

Head Type	
String Post	STANDARD. MG. HAP. HAP-A. HAP-M
Finishes	C. GG. B. CK2. XN. XC. XG
Gear ratio	1 : 15
e.g.	SGS510-S5-L-HAPM SGS510-B07-R-HAP SGS510-L5



※この機種の MG および H.A.P-M は DSL 仕様です。(4 頁参照)

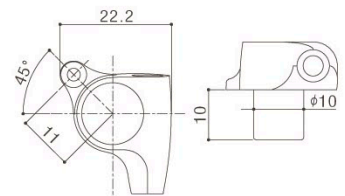

SGL510

Head Type	
String Post	STANDARD. MG. HAP. HAP-A. HAP-M
Finishes	C. GG. B. CK2. XN. XC. XG
Gear ratio	1 : 18
e.g.	SGL510-P2 SGL510-L5 HAPA SGL510-H01 MG



※この機種の MG および H.A.P-M は DSL 仕様です。(4 頁参照)

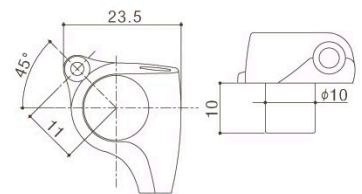

SGV510

Head Type	
String Post	STANDARD. MG. HAP. HAP-A. HAP-M
Finishes	C. GG. B. CK2. XN. XC. XG
Gear ratio	1 : 18
e.g.	SGV510-L5 SGV510-P1 MG SGV510-EN01 HAPA



※この機種の MG および H.A.P-M は DSL 仕様です。(4 頁参照)

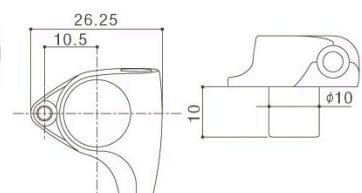

Finishes : C (Chrome), GG (Gold), B (Black Chrome), CK2 (Cosmo Black 2), XN (X-Nickel), XC (X-Chrome), XG (X-Gold)

軸寸法	STANDARD	MG	HAP/L3+R3	HAP/L6orR6	HAPA/L3+R3	HAPM/L3+R3	HAPM/L6orR6

SG510 Series BUTTON OPTION

ツマミは以下よりお選び頂くことが出来ます。(原寸比:約 50%)

* Zinc および Aluminum のボタンは本体と同色となります。



全タイプで指定可



L3+R3 専用

※6 連配列には不向きです。



SGS510Z

Head Type	
String Post	STANDARD. MG. HAP. HAP-A. HAP-M
Finishes	C. GG. B. CK2. XN. XC. XG
Gear ratio	1 : 18
e.g.	SGS510Z-EN07 SGS510Z-BS5-L HAP SGS510Z-P7-L MG



※この機種の MG および H.A.P-M は DSL 仕様です。(4 頁参照)



SGL510Z

Head Type	
String Post	STANDARD. MG. HAP. HAP-A. HAP-M
Finishes	C. GG. B. CK2. XN. XC. XG
Gear ratio	1 : 21
e.g.	SGL510Z-L5 SGL510Z-EN01 MG SGL510Z-P1 HAPM



※この機種の MG および H.A.P-M は DSL 仕様です。(4 頁参照)



SGV510Z

Head Type	
String Post	STANDARD. MG. HAP. HAP-A. HAP-M
Finishes	C. GG. B. CK2. XN. XC. XG
Gear ratio	1 : 21
e.g.	SGV510Z-BL5 HAP SGV510Z-S5 SGV510Z-L5 HAPM



※この機種の MG および H.A.P-M は DSL 仕様です。(4 頁参照)



* 510Z の「Z」は究極を意味し、1:21の高ギア比 (SGS510Z は 1:18) を実現しています。

SG503

Head Type	
String Post	STANDARD. MG. HAP. HAP-A. HAP-M
Finishes	C. GG. B. CK2
Gear ratio	1 : 15
e.g.	SG503-P7-L HAPM SG503-07-R HAP SG503-05

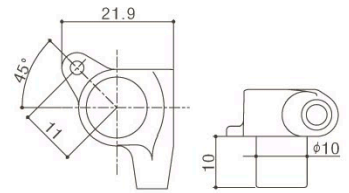

SG301

Head Type	
String Post	STANDARD. MG. HAP. HAP-A. HAP-M
Finishes	C. GG. B. CK2
Gear ratio	1 : 18
e.g.	SG301-EN01 SG301-01 MG SG301-P1

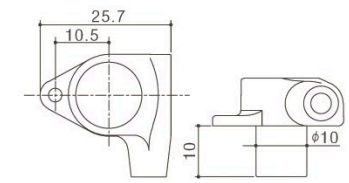

SG360

Head Type	
String Post	STANDARD. MG. HAP. HAP-A. HAP-M
Finishes	C. GG. B. CK2
Gear ratio	1 : 14
e.g.	SG360-M07 SG360-05-R HAP SG360-H01 MG

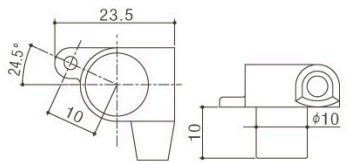

SG381

Head Type	
String Post	STANDARD. MG. HAP. HAP-A. HAP-M
Finishes	C. GG. B. CK2
Gear ratio	1 : 16
e.g.	SG381-05-L HAPM SG381-B07-R HAP SG381-04

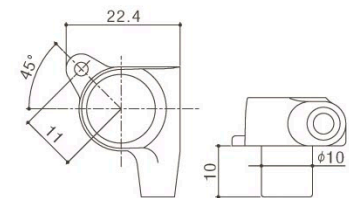

SGM

Head Type	
String Post	STANDARD. MG
Finish	C
Gear ratio	1 : 16
e.g.	SGM-05P1-L SGM-07-R-MG SGM-20

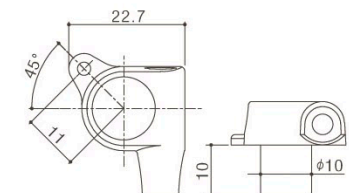

軸寸法	STANDARD	MG	HAP/L3+R3	HAP/L6orR6	HAPA/L3+R3	HAPM/L3+R3	HAPM/L6orR6

SG Series BUTTON OPTION

ツマミは以下よりお選び頂くことができます。(原寸比: 約 50%)

* Zinc および Aluminum のボタンは本体と同色となります。



全タイプで指定可



L3+R3 専用 ※6 連配列には不向きです。



SE510 SERIES

Electric and Acoustic Guitar Machine Heads

オープンギアタイプのマシンヘッドは、構造上ロトマチックタイプのマシンヘッドに比べ性能や耐久性が劣ると言われています。その原因に本体とブッシュが分離式の為、ギターに取り付ける際、ポストをブッシュ穴のセンターに取り付けるのが難しいことが挙げられます。この問題を解消するため、SE510 シリーズは本体底部にセルフセンターガイドを設け、ロックソリッドストリングポストとの併用で取付の偏芯を最小限に抑えています。更に GOTOH 独自の構造によって性能や耐久性が向上した SE510 シリーズは、今までとは別次元のサウンドを貴方に体感させることでしよう。

SE510

Head Type	
String Post	STANDARD
Finishes	N. C. GG. B. CK2. XN. XC. XG
Gear ratio	1 : 15
e.g.	SE510-05M SE510-SL

*Self-stop nut Pat.

*Self-center guide U.S. PAT.



Chrome

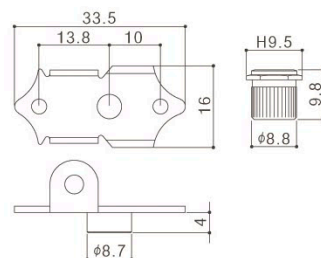

SE510M

Head Type	
String Post	STANDARD
Finishes	N. C. GG. B. CK2. XN. XC. XG
Gear ratio	1 : 15
e.g.	SE510M-05MA SE510M-P5W

*Self-stop nut Pat.

*Self-center guide U.S. PAT.



Gold

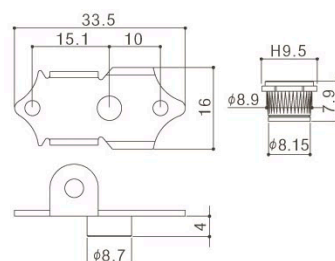

SE510W

Head Type	
String Post	STANDARD
Finishes	N. C. GG. B. CK2. XN. XC. XG
Gear ratio	1 : 15
e.g.	SE510W-06M SE510W-SL

*Self-stop nut Pat.

*Self-center guide U.S. PAT.



Black Chrome

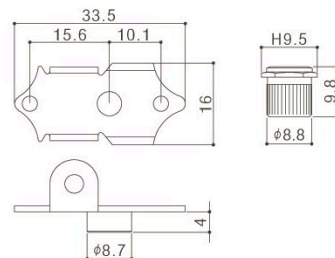

軸寸法	SE510	SE510M / SE510W	SE700	SE770 / SE780

Finishes : N (Nickel), C (Chrome), GG (Gold), B (Black Chrome), CK2 (Cosmo Black 2), XN (X-Nickel), XC (X-Chrome), XG (X-Gold)

FOR SLOTTED HEAD

SEP700

SEP770

SEP780

P 軸専用ブッシュ打込治具

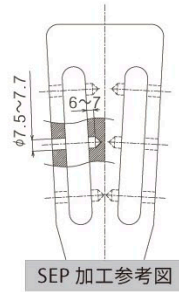
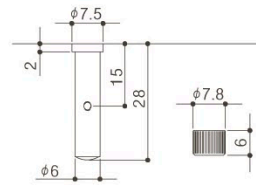

SE SERIES

Electric and Acoustic Guitar Machine Heads

SE700

Head Type	
String Post	STANDARD
Finishes	N. C. GG. B. CK2. XN. XC. XG
Gear ratio	1 : 15
e.g.	SE700-06M SE700-P5W

*Self-stop nut Pat.

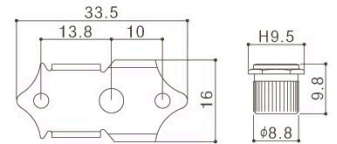

SE770

Head Type	
String Post	STANDARD
Finishes	N. C. GG. B. CK2. XN. XC. XG
Gear ratio	1 : 15
e.g.	SE770-05M SE770-B5

*Self-stop nut Pat.

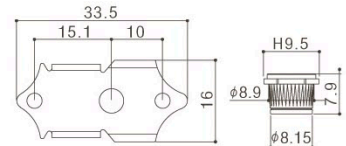

SE780

Head Type	
String Post	STANDARD
Finishes	N. C. GG. B. CK2. XN. XC. XG
Gear ratio	1 : 15
e.g.	SE780-SLB SE780-06M

*Self-stop nut Pat.

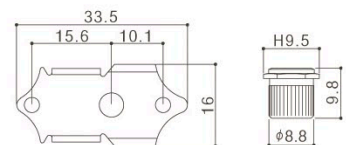

SE510 / SE Series BUTTON OPTION

ツマミは以下よりお選び頂くことが出来ます。(原寸比:約 50%)

* Zinc のボタンは本体と同色となります。



L3 + R3 専用



05M

(Zinc)



06M

(Zinc)



SL

(Plastic)



SLB

(Plastic)



B5

(Plastic)



M5

(Plastic)



P5W

(Plastic)



P5R

(Plastic)



クルーソンタイプのマシンヘッドは、構造上ロッドマチックタイプ
のマシンヘッドに比べ性能や耐久性が劣ると言われています。
SD510 シリーズはセルフセンターガイドとロックソリッドストリン
グポストを採用し取付の偏芯を最小限に抑え、性能向上を図って
います。またツマミの回転を安定させるためのトルクバランサーを
有し、各 부품の材料を的確に使い分けることで性能や耐久
性はもとより音質も向上させています。

SD510

Head Type	
String Post	STANDARD, MG, H.A.P., H.A.P.-A, H.A.P.-M
Finishes	N. GG. B. CK2. XN. XC. XG
Gear ratio	1 : 15
e.g.	SD510-05M SD510-SL HAPA

*Self-center guide U.S. PAT.

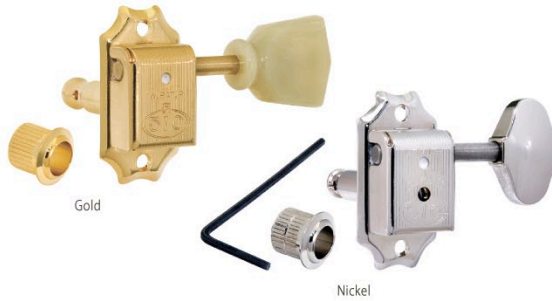

※この機種 MG および H.A.P.-M は DSL 仕様です。(4頁参照)

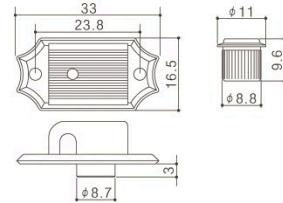

SDS510

Head Type	
String Post	STANDARD, MG, H.A.P., H.A.P.-M
Finishes	N. GG. B. CK2. XN. XC. XG
Gear ratio	1 : 15
e.g.	SDS510-05M-L MG SDS510-P5W R

*Self-center guide U.S. PAT.



※この機種 MG および H.A.P.-M は DSL 仕様です。(4頁参照)

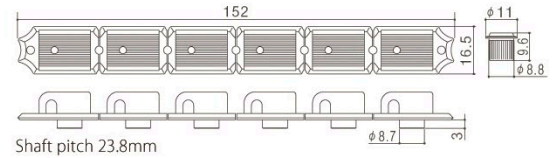

軸寸法	SD510 STANDARD	SDS510 STANDARD	MG	SD510 HAP	SDS510 HAP	HAPA	SD510 HAPM	SDS510 HAPM
					1ST~3ST 4ST~6ST			1ST~3ST 4ST~6ST

SD510 / SD Series BUTTON OPTION

ツマミは以下よりお選び頂くことが出来ます。(原寸比: 約 50%)

* Zinc のボタンは本体と同色となります。



全タイプ共通



05M
(Zinc)



05MA
(Plastic)



06M
(Zinc)



SL
(Plastic)



SLB
(Plastic)



B5
(Plastic)



M5
(Plastic)



P5W
(Plastic)



P5R
(Plastic)

SD SERIES

SD90

Head Type	
String Post	STANDARD, MG, H.A.P., H.A.P-A, H.A.P-M
Finishes	N, GG, B, CK2
Gear ratio	1 : 15
e.g.	SD90-SL SD90-SLB MG

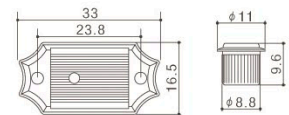

SD91

Head Type	
String Post	STANDARD, MG, H.A.P., H.A.P-M
Finishes	N, GG, B, CK2
Gear ratio	1 : 15
e.g.	SD91-05M-L HAPM SD91-M5-R

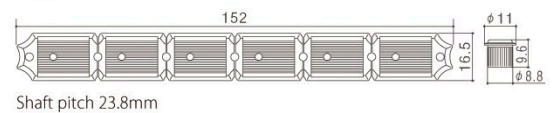

軸寸法	SD90 STANDARD	SD91 STANDARD	MG	SD90 HAP	SD91 HAP	HAPA	SD90 HAPM	SD91 HAPM
				1ST~3ST	4ST~6ST			1ST~3ST 4ST~6ST

Planetary Banjo Tuners



高い加工技術と新発想により開発されたチューナーです。従来品に比べ（当社比）チューニング精度が格段に向上し、スムーズな使用感を体感できます。特に5弦用チューナーはその構造から根本的に見直し、今までの問題点を解消したスーパーチューナーです。

SPBJ-4

Finishes	N, C, GG
Gear ratio	1 : 4
e.g.	SPBJ-4-AI SPBJ-4-PW

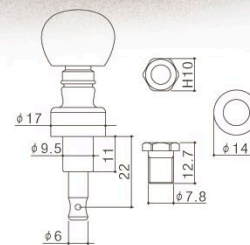

SPBJ-5

Finishes	N, C, GG
Gear ratio	1 : 13
e.g.	SPBJ-5-PW SPBJ-5-AIB

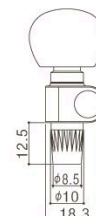

SPBJ BUTTON OPTION

ツマミは以下よりお選び頂くことが出来ます。（原寸比：約50%）



PW
(Plastic)



AI
(Plastic)



AIB
(Plastic)

Finishes : N (Nickel), C (Chrome), GG (Gold)

STEALTH

The world's smallest Tuning-key

GOTOH STEALTH-Key (ステルス・キー) pat.p

世界最小、最軽量の超小型ペグ

ギター、ウクレレ、その他20kg以内の張力を有する楽器に使用可能です。

*注) 20kgを超える張力を掛けられた場合は保証の対象外となります。



STEALTH-KEY SERIES

ST31	ST31	STM31	STP31	STS31	STV31
Head Type	GUITAR 			UKULELE 	
Finishes	C. GG. CK2				
Gear ratio	1 : 18 Micro worm gear				
e.g.	ST31-SB2 STP31-SB3 STM31-SB5L				



For Electric and Acoustic Guitar
For Ukulele

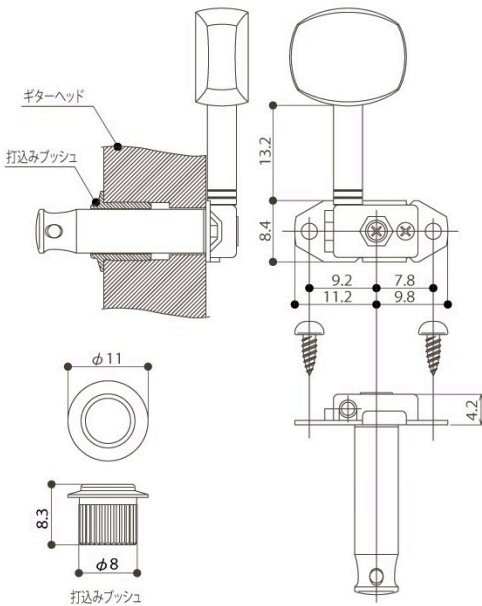

Finishes : N (Nickel), C (Chrome), GG (Gold), CK2 (Cosmo Black 2)

無限に広がる楽器デザインの可能性

写真：僅か 11.9g の ST 31

※Post : STANDARD, Button : SB5 搭載時で打込みプッシュとビスを外した状態で計量。



レイアウトの一例

図 1
ヘッドに埋設した例



図 2
ヘッド側面への取付例



図 3
ヘッド前面への取付例
*For Ukulele

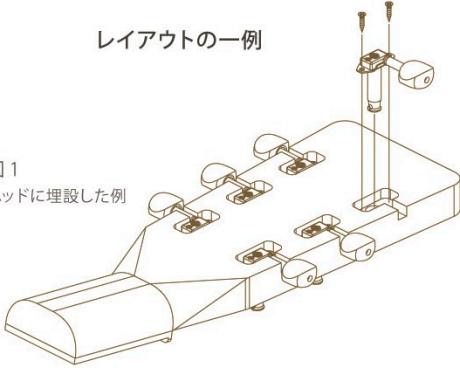

小型、軽量

- 縦8.5mm、横21mm、高さ4.5mmの超小型ハウジングを実現しました。
- 従来のギター用ペグと比較し、1/2~1/3の重量に軽量化しました。
(ギター用軸+アルミ製オリジナルツマミ仕様で1ヶあたり11g~12g)

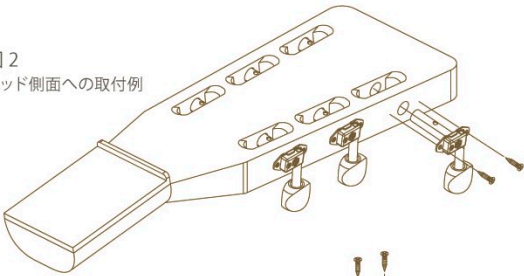
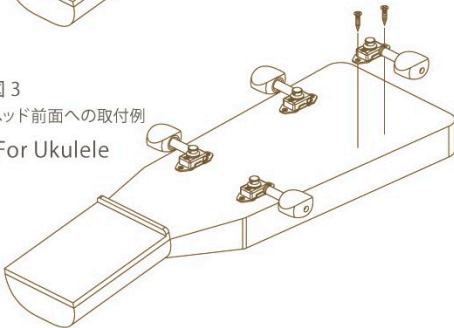
高精度

- 18 : 1のギア比を誇るマイクロ・ウォームギアを内蔵。微細なチューニングが可能です。
- すべての部品を高精度ミクロン加工することにより実現したスケールと強度。
- あらゆる稼動部分にメタル軸受け、メタルワッシャーを装備しました。小型でも滑らかな動きを実現します。

ユーザビリティ

- 軸、ツマミを選択することによりエレキギター、アコースティックギター、ウクレレ、その他、多種の楽器に使用可能です。
(張力は 20kg 以内)
- 軸はカバー上面 (Gotoh 刻印がある面) に取り付けることも可能です。*図 3 参照
(張力は 10kg 以内)
- 楽器ヘッドに埋設したり、ヘッド表側に設置したり、ヘッド側面に設置するなど、これまで不可能だった多彩なレイアウトができ、楽器の可能性を大きく広げます。
*図 1、図 2、図 3 参照
- 軽量化により楽器ボディとヘッドのバランスを調整しやすくなります。長時間の演奏も疲労が軽減されます。
- ハウジングは格調高いサテンブラックを基調とし、他の部品も高級感を損なわない仕上げを施しています。
- ツマミ・トルク調整ビスは緩み止め機構を採用。長期間の使用にも緩みにくくなっています。ただし、ワッシャーの磨耗による緩みは発生するので、調整は必要です。
- 主要部品の材質は錆に強く変化しにくいステンレス、アルミ、プラスで構成されています。
*注：ステンレスは錆にくいとされていますが、使用環境により錆が発生する場合がございます。

エコロジー

- 地球環境のため材料を少なくし、資源を大切に使うことは重要な課題になっています。STEALTHは従来品の1/2~1/3に材料を削減しました。
- 資源を再生して使用することは環境を守るために必要です。STEALTHの主要部品はすべてリサイクル可能な材質で構成されています。また、全部品が分解可能に作られています。使用終了時、分解してそれぞれの材質ごとに専門業者へ渡せば、資源のリサイクルが可能になります。

STEALTH Key 軸寸法

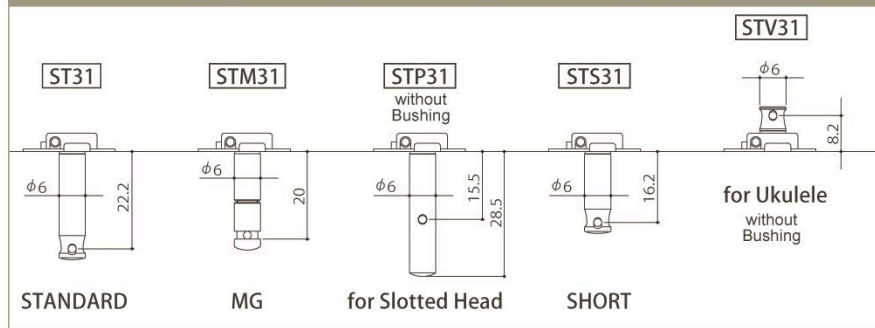

STEALTH Key BUTTON OPTION

ツマミは以下よりお選び頂くことができます。(原寸比：約 50%)

ボタンの素材は全てアルミ製です。



中間軸レスタイプ



GOTOHの最先端加工技術から生み出された部品達。その部品に命を与え、世界最高のマシンヘッドを作り上げるため繊細な感覚で妥協することなく完成品へと組み上げていく職人技。部品ひとつひとつ、職人ひとりひとりの拘りがクラシック用マシンヘッド 35G510 シリーズを支え、世界中のユーザーから高い信頼性と評価を得ています。

*イメージ写真はレギュラー仕様ではありません。

* P 軸「35P Rock-Solid」仕様はギターヘッドに段付加工が必要になりますのでご注意ください。(加工参考図参照)

35G510AM

String Post	35G. 35AR. 35P
Finishes	XN. XG. XCK2
Gear ratio	1 : 16
e.g.	35G510AM-BB 35G510AM-KM
Material	Hard Aluminum

X-Nickel

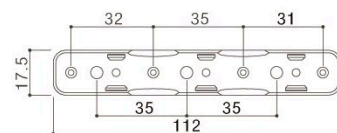

35G510MFB

String Post	35G. 35AR. 35P
Finish	SB
Gear ratio	1 : 16
e.g.	35G510MFB-BM 35G510MFB-P
Material	Aluminum Bronze

Solid Brass

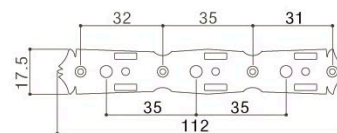



35G510MF

String Post	35G. 35AR. 35P
Finishes	XN. XG. XCK2
Gear ratio	1 : 16
e.g.	35G510MF-M 35G510MF-EN

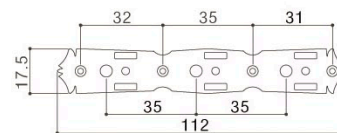
X-Cosmo Black 2

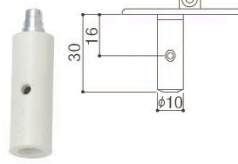

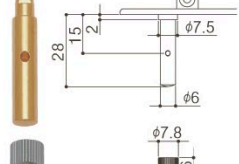
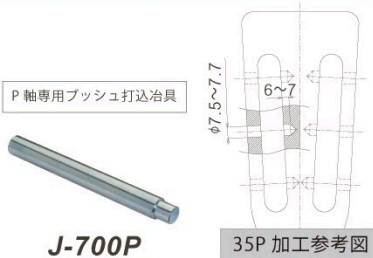
軸寸法	35G	35AR	35P	
				
		AR ARB		J-700P 35P 加工参考図

35G510 Series BUTTON OPTION

ツマミは以下よりお選び頂くことが出来ます。(原寸比: 約 50%)



M

(Shell)



BM

(Shell)



EN

(Wood)



KB

(Plastic)



KM

(Plastic)



BB

(Plastic)



P

(Plastic)

35G510C

String Post 35G. 35AR. 35P

Finish GG

Gear ratio 1 : 16

e.g. 35G510C-BM
35AR510C-M

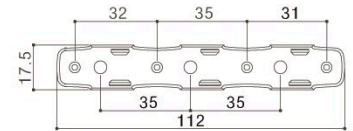

35G510P

String Post 35G. 35AR. 35P

Finish GG

Gear ratio 1 : 16

e.g. 35G510P-P
35AR510P-KB

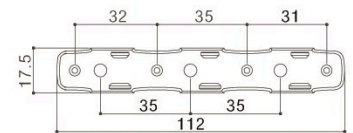

35G510QC

String Post 35G. 35AR. 35P

Finish MTG

Gear ratio 1 : 16

e.g. 35G510QC-KM
35AR510QC-EN

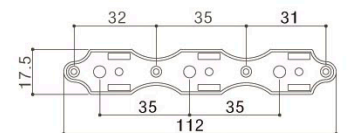

35G510S

String Post 35G. 35AR. 35P

Finishes N. CK2. XN. XG

Gear ratio 1 : 16

e.g. 35G510S-P
35P510S-BB

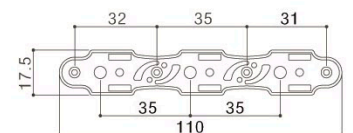

35G SERIES

Classic Guitar Machine Heads

* P軸「35P Rock-Solid」仕様はギターヘッドに段付加工が必要になりますのでご注意ください。(加工参考図参照)

35G3600

Finish FG (Flash Gold)



String Post
35G. 35P

Gear ratio
1 : 14

e.g.
35G3600-BB
35P3600-2W

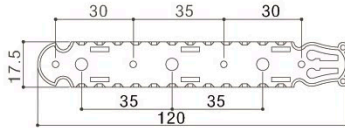

35G3600T

Finish Two-Tone (Ni, GG)



String Post
35G. 35P

Gear ratio
1 : 14

e.g.
35G3600T-1R
35P3600T-EN

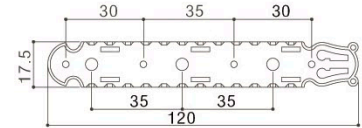

35G1800



String Post
35G. 35P

Finish
SB

Gear ratio
1 : 14

e.g.
35G1800-2M
35P1800-1W

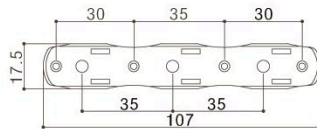

35G1600



String Post
35G. 35P

Finish
GG

Gear ratio
1 : 14

e.g.
35G1600-2R
35P1600-1M

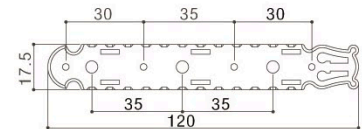
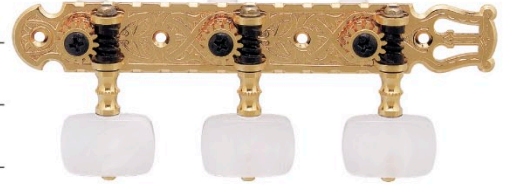

35G620



String Post
35G. 35P

Finish
GG

Gear ratio
1 : 14

e.g.
35G620-EI
35P620-EW

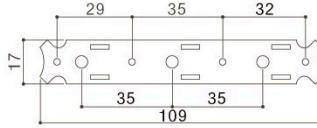

35G Series BUTTON OPTION

ツマミは以下よりお選び頂くことが出来ます。



軸寸法

for 35G420
35G350

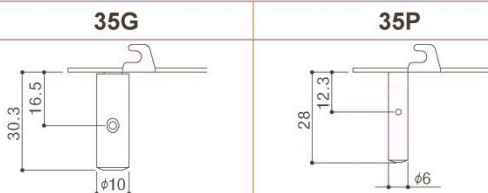

軸寸法

35G

35P

for 35G3600, 35G1800, 35G1600, 35G620

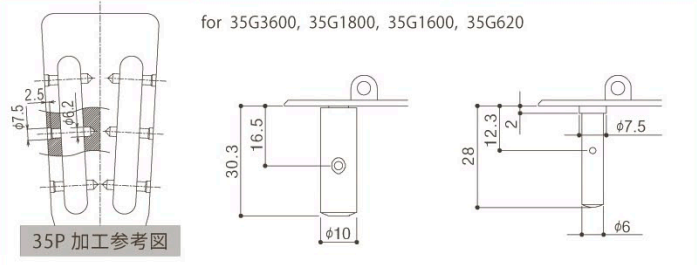

35G420

String Post
35G. 35P

Finish
SG

Gear ratio
1 : 14

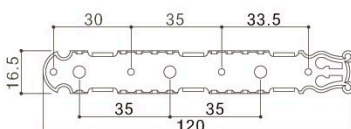

35G350

String Post
35G. 35P

Finish
N

Gear ratio
1 : 14

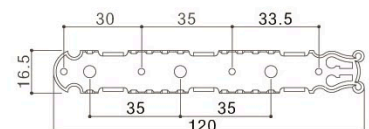

MANDOLIN MACHINE HEADS

MA40

Finishes
N. GG

Gear ratio
1 : 14

e.g.
MA40-MM
MA40-MP

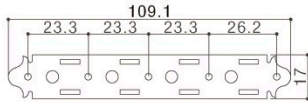

MA40R

Finishes
N. GG

Gear ratio
1 : 14

e.g.
MA40R-MP
MA40R-MB

Reverse gearing

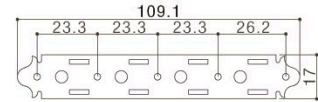

※ロット生産品です。
1色につき30sets以上まとめてご注文ください。

MF40

Finishes
N. GG

Gear ratio
1 : 14

e.g.
MF40-MB
MF40-MP

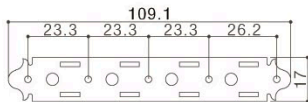
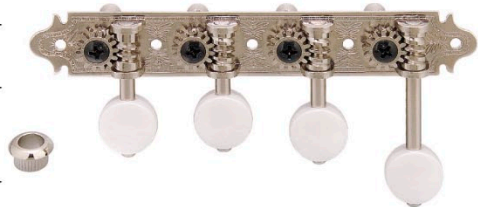

MF40R

Finishes
N. GG

Gear ratio
1 : 14

e.g.
MF40R-MP
MF40R-MM

Reverse gearing

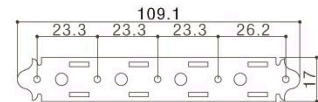

※ロット生産品です。
1色につき30sets以上まとめてご注文ください。

軸寸法

for MA40, MA40R, MF40, MF40R

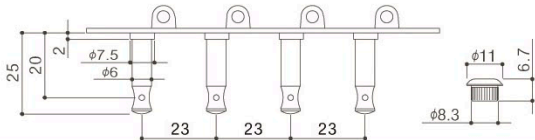

MA40/MF40 BUTTON OPTION

ツマミは以下よりお選び頂くことができます。

(原寸比: 約 50%)



MP
(Plastic)



MB
(Plastic)



MM
(Plastic)

M120

Finishes
N. GG

Gear ratio
1 : 14

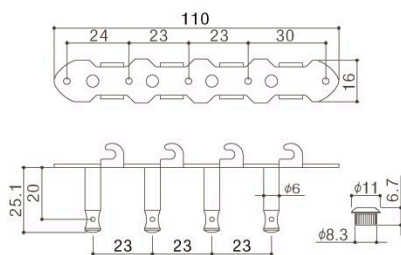

M120S

Finishes
N. GG

Gear ratio
1 : 14

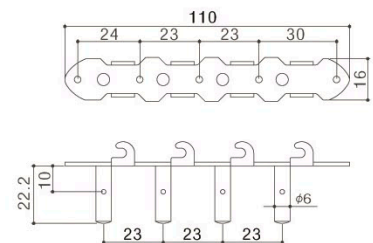

RES-O-LITE Series

Bass Machine Heads

超軽量ベースマシンヘッド

ベースギター特有の問題としてマシンヘッドの重量が重くヘッド落ちが起こりやすい事があります。5弦や6弦ベースの出現で、このアンバランスはより深刻なものとなり、長時間の演奏を不快な状況にしまいます。この問題を解消すべく、RES-O-LITEシリーズは開発されました。特殊ジュラルミンを主体に驚異的な軽量化を実現。GB350はRock-Solidの採用で弦の振動をより強力にヘッドに伝達するとともにチューニングの安定とスムーズな巻き上げ感を実現しました。

重量比較 (1ヶ当たり)

GOTOH 旧モデル		RES-O-LITE Bass シリーズ	
GB70	64.4g	GB350	40.0g
GB9	115.5g	GB640	66.9g
GB30	83.0g	GB528	59.2g

GB350

RES-O-LITE

Head Type



Finishes

C. GG. B. CK2. XN. XC. XG

Gear ratio

1 : 20

Aluminum shaft, worm and gear
Plastic button (Plated)
World Design Pat.



Black Chrome

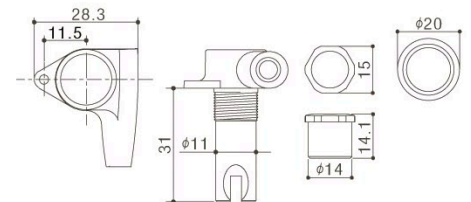

GB640

RES-O-LITE

Head Type



Finishes

N. GG. B. CK2. XN. XC. XG

Gear ratio

1 : 28

Left side only



Nickel

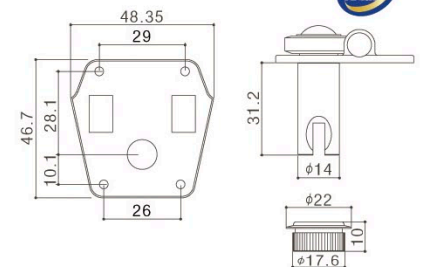

GBR640

RES-O-LITE

Head Type



Finishes

N. GG. B. CK2. XN. XC. XG

Gear ratio

1 : 28

Reverse wind / Left side only



Cosmo Black 2

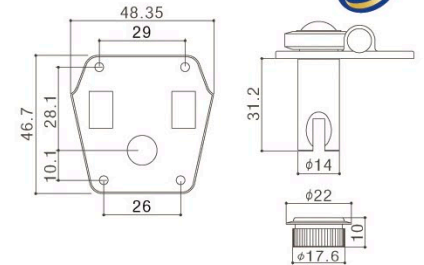

GB528

RES-O-LITE

Head Type



Finishes

N. GG. B. CK2. XN. XC. XG

Gear ratio

1 : 26



Gold

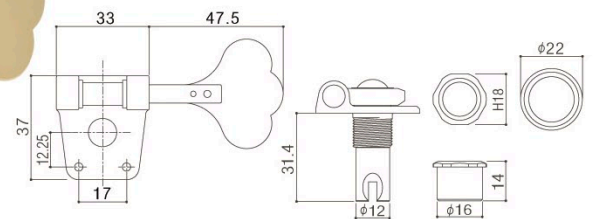

GB528S

RES-O-LITE

Head Type



Finishes

N. GG. B. CK2. XN. XC. XG

Gear ratio

1 : 26



Nickel

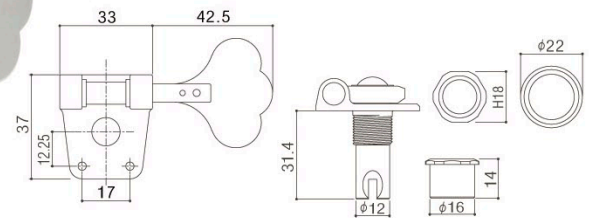

Finishes: N (Nickel), C (Chrome), GG (Gold), B (Black Chrome), CK2 (Cosmo Black 2), XN (X-Nickel), XC (X-Chrome), XG (X-Gold)



Bass Machine Heads

GB720

Head Type	
Finishes	C. GG. B. CK2
Gear ratio	1 : 20

Aluminum shaft
Plastic button (Plated)
World Design Pat.



Gold

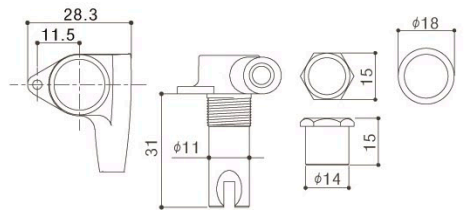

GB707

Head Type	
Finishes	C. GG. B. CK2
Gear ratio	1 : 20

World Design Pat.



Cosmo Black 2

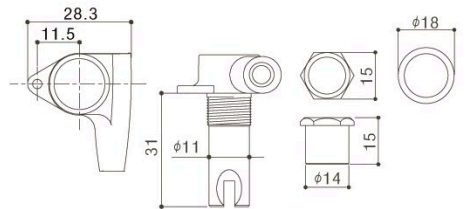

Bass Machine Heads

GB1

Head Type	
Finishes	N. GG. B. CK2
Gear ratio	1 : 20



Gold

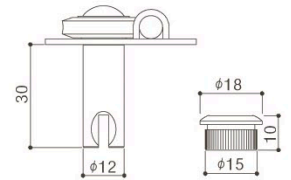
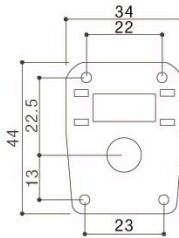

GB2

Head Type	
Finishes	N. GG. B. CK2
Gear ratio	1 : 26



Nickel

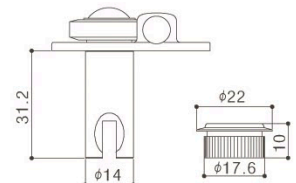
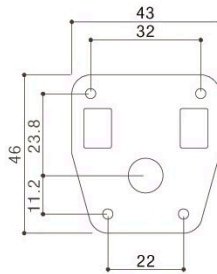

GB29

Head Type	
Finishes	N. GG. B. CK2
Gear ratio	1 : 26

Reverse wind



Gold

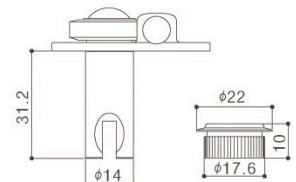
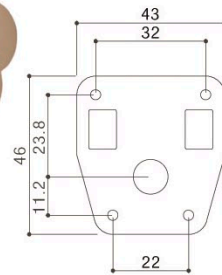

GB11W

Head Type	
Finishes	C. GG. B. CK2
Gear ratio	1 : 20



Cosmo Black 2

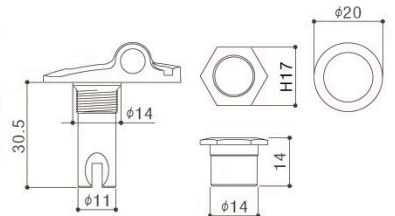
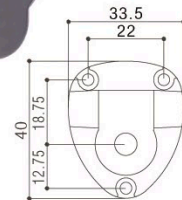

FB3

Head Type	
Finishes	N. GG. B. CK2
Gear ratio	1 : 20



Nickel

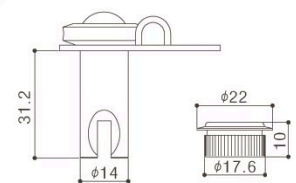
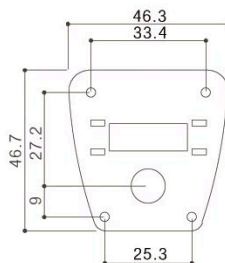

Ukulele Peg



UK12

Finishes	N. GG
Gear ratio	1 : 14
e.g.	UK12-05MA UK12-B5

特殊アルミ材から成る（一部部品を除く）超軽量ペグ

1 : 14 の減速比でチューニングの操作性も良好。演奏時に逆転する心配もありません。しかも超軽量なため、ヘッド落ちの問題も解消されます。

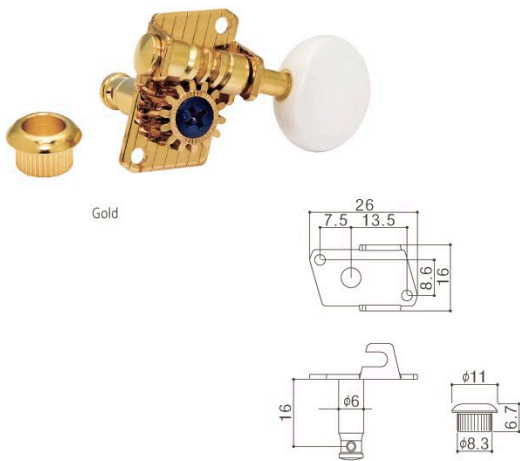

UK700

Finishes	N. GG
Gear ratio	1 : 15
e.g.	UK700-M5 UK700-B5

H.A.P. システム搭載のハイパフォーマンスペグ

ギター用糸巻きで定評のある H.A.P. システムを標準装備。ヘッド厚 9 ~ 1.6 mm のウクレレに対応でき、軸の高さを調整することで弦テンションも変えることができます。

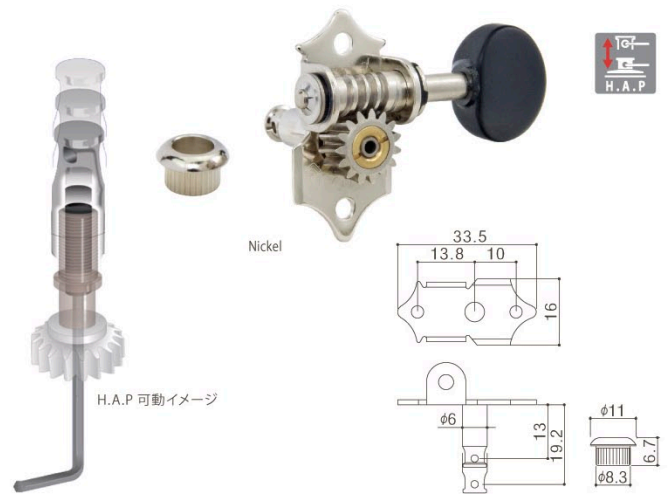

UK12 / UK700 BUTTON OPTION

ツマミは以下よりお選び頂くことが出来ます。（原寸比：約 50%）



05MA
(Plastic)



B5
(Plastic)



M5
(Plastic)

UKA

Finishes	N. GG
Gear ratio	1 : 1
e.g.	UKA-3W UKA-4B

軽量化のため主要部品に特殊アルミ材を使用し、通常アルミ製品に施される染色ではなくメッキフィニッシュをする事で、高い耐摩耗性を得ています。また、逆転を防ぎ滑らかな回転を得るため独自の機構を持たせています。



UKB

Finishes	N. GG
Gear ratio	1 : 1



UKA BUTTON OPTION

ツマミは以下よりお選び頂くことが出来ます。（原寸比：約 50%）



3W
(Plastic)



3R
(Plastic)



4I
(Plastic)







4B
(Plastic)

Finishes : N (Nickel), GG (Gold)

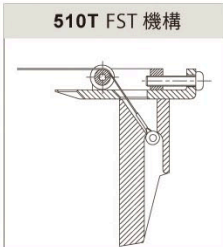
510T シリーズは、従来のヴィンテージスタイルにはこだわらず、トレモロ装置としての機能を追求しました。クリアランスの少ない独自のアームシステムを搭載。可動の支点となるエッジ部の強度と耐摩耗性を確保する為、プレートには高硬度のクロームモリブデン鋼を採用。精密な加工とハイレベルな熱処理で仕上げました。支点部はシンクロナイズドタイプと同じ6点支持タイプと、スタッドロック (PAT.)*を採用した2点支持アンカーナットタイプがあります。またサドルとボールエンド間で弦のプレートへの干渉を避ける為に独自の形状に成型された FST 機構 (PAT.) を持つブロックやユニットの中立バランスを保つパワースプリングを装備した事で、アミング後のチューニングの復元性を飛躍的に向上させました。510TS はご要望の多かったスチールブロックが標準仕様になっています。

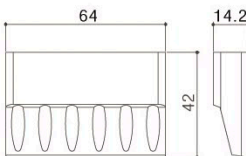
*スタッドロック (PAT.) - アンカーとスタッドボルトのクリアランスを機械的に固定し、ボディへの音の伝達ロスをなくしたシステム。

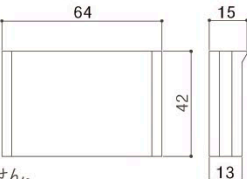
510T ブロック		510TS ブロック		
<p>510T FST 機構</p> 				
※510TS は FST 機構ではありません。				

EV510T-BS EV510TS-BS

Finishes C. GG. B. CK2. XN. XC. XG

Brass saddle
String pitch 10.8mm
Stud lock-Pat.

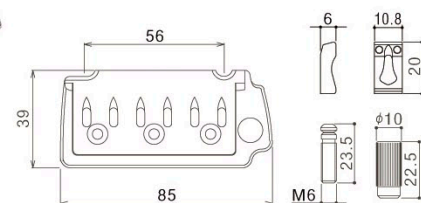

EV510T-FE EV510TS-FE

Finishes C. GG. B. CK2. XN. XC. XG

Steel saddle,
String pitch 10.8mm
Stud lock-Pat.

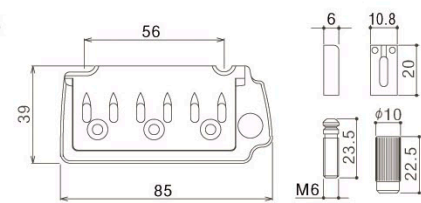

Finishes : C (Chrome), GG (Gold), B (Black Chrome), CK2 (Cosmo Black 2), XN (X-Nickel), XC (X-Chrome), XG (X-Gold)

510T-BS1 510TS-BS1

Finishes C. GG. B. CK2

Brass saddle
String pitch 10.8mm
Stud lock-Pat.



Cosmo Black 2

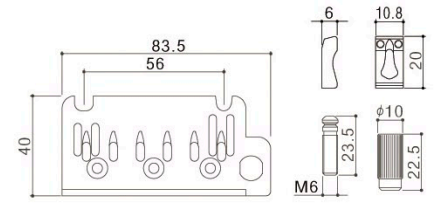

510T-FE1 510TS-FE1

Finishes C. GG. B. CK2

Steel saddle,
String pitch 10.8mm
Stud lock-Pat.



Gold

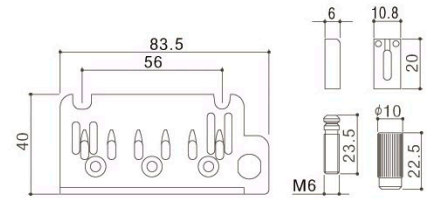

510T-SF1 510TS-SF1

Finishes C. GG. B. CK2

Steel saddle(sheet metal),
String pitch 10.8mm
Stud lock-Pat.



Chrome

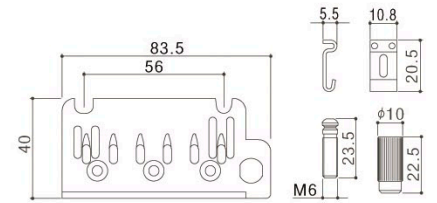

510T-BS2 510TS-BS2

Finishes C. GG. B. CK2

Brass saddle
String pitch 10.8mm



Gold

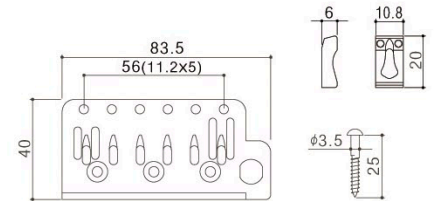

510T-FE2 510TS-FE2

Finishes C. GG. B. CK2

Steel saddle,
String pitch 10.8mm



Chrome

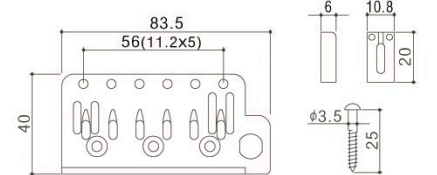

510T-SF2 510TS-SF2

Finishes C. GG. B. CK2

Steel saddle(sheet metal),
String pitch 10.8mm



Black Chrome

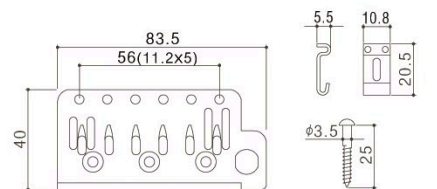

TREMOLO UNITS & LOCK NUTS

Tremolo Units & Lock Nuts

GE1996T

Finishes C. GG. B. CK2

Specially processed steel saddle, string pitch 10.8mm Stud lock-Pat.

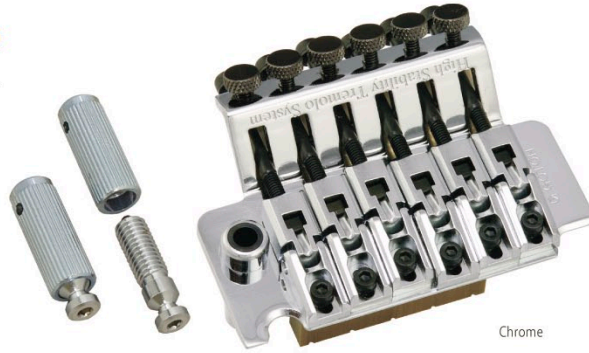

Chrome

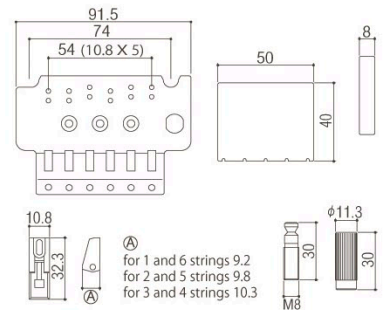

FGR-1 FGR-2

Finishes C. GG. B. CK2

GHL-1 GHL-2

Finishes C. GG. B. CK2



Gold

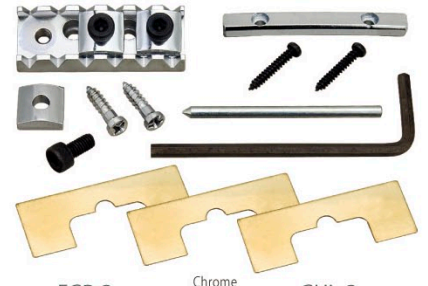
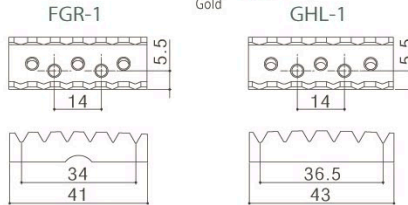

Chrome

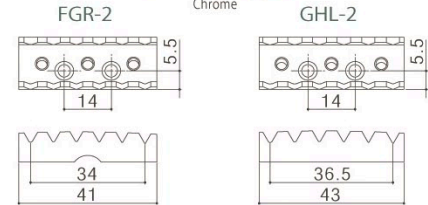

GE101T

Finishes C. GG. B. CK2

Steel saddle (sheet metal), string pitch 11.3mm



Black Chrome

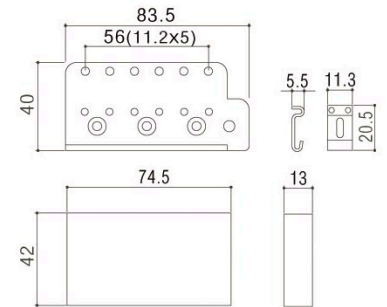

GE102T

Finishes C. GG. B. CK2

Steel saddle, string pitch 11.3mm

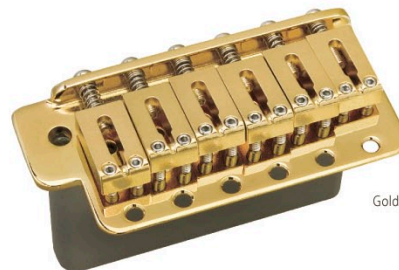

Gold

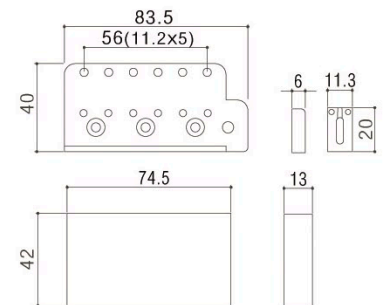

GE101TS

Finishes C. GG. B. CK2

Steel block, Steel saddle(sheet metal) with U.S.A. threads screws, string pitch 11.3mm



Chrome

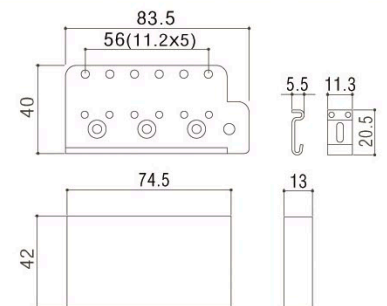



510UB

Finishes : C. GG. B. CK2. XN. XC. XG

Hard zinc saddle
Stud lock-Pat.

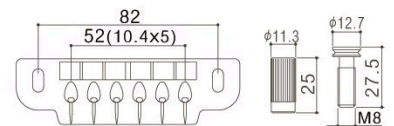

510FA

Finishes : C. GG. B. CK2. XN. XC. XG

Material / Aluminum
Stud lock-Pat.

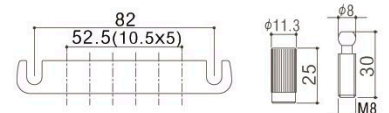

510FB

Finishes : C. GG. B. CK2. XN. XC. XG

Brass saddle
Stud lock-Pat.

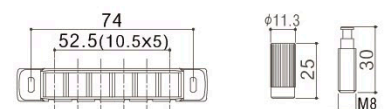

Guitar Bridges & Tailpieces

GTC101

Finishes C. GG. B. CK2

Brass saddle.
string pitch 10.5mm

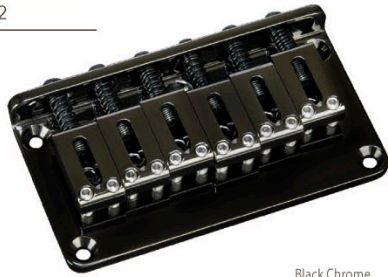

Black Chrome

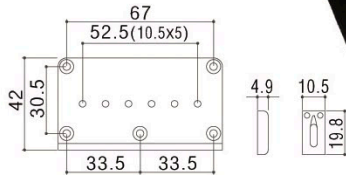

GTC102

Finishes C. GG. B. CK2

Steel saddle.
string pitch 10.5mm

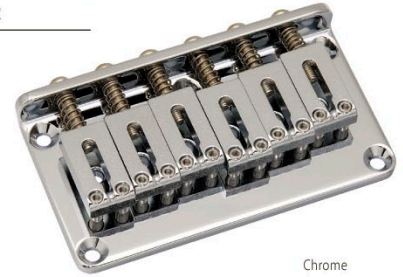

Chrome

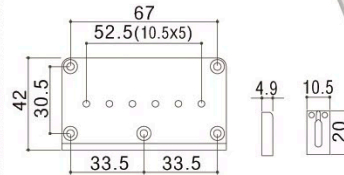

GTC201

Finishes C. GG. B. CK2

Brass saddle.
string pitch 10.8mm

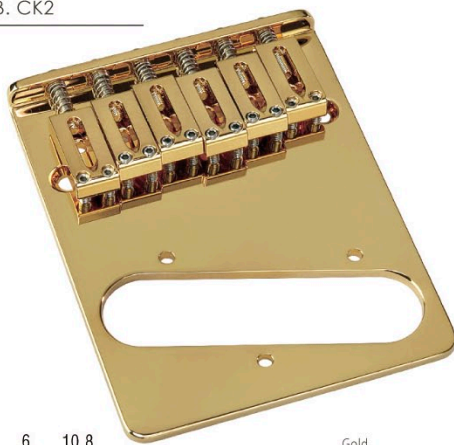

Gold

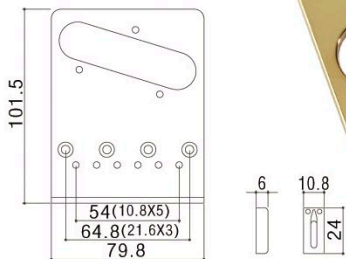

GTC202

Finishes C. GG. B. CK2

Steel saddle.
string pitch 10.8mm



Chrome

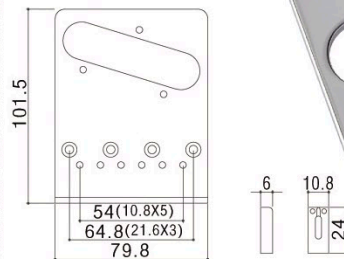

GTC12

Finishes C. GG. B. CK2

Hard zinc saddle,
string pitch 10.5mm
for 12-strings



Gold

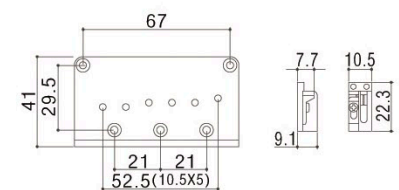

GE101Z

Finishes N. C. GG. B. CK2

Material Zinc diecast



Cosmo Black 2

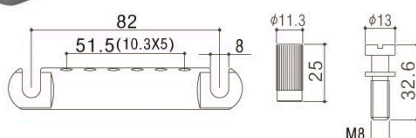

GE101Z-T

Finishes N. C. GG. B. CK2

Material Zinc diecast



Chrome

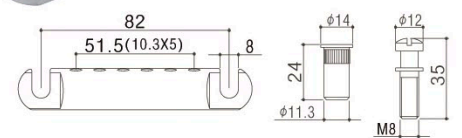

GE101A

Finishes | N. C. GG. B. CK2

Material | Aluminum

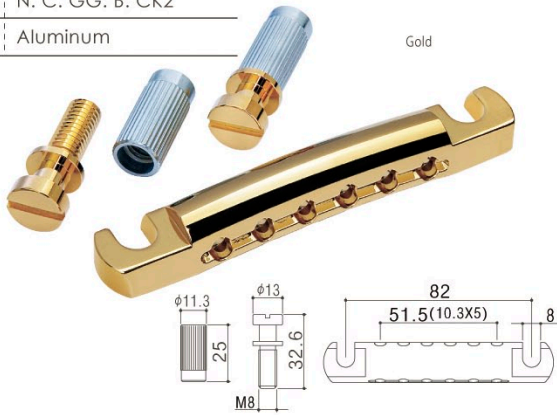

GE101A-T

Finishes | N. C. GG. B. CK2

Material | Aluminum

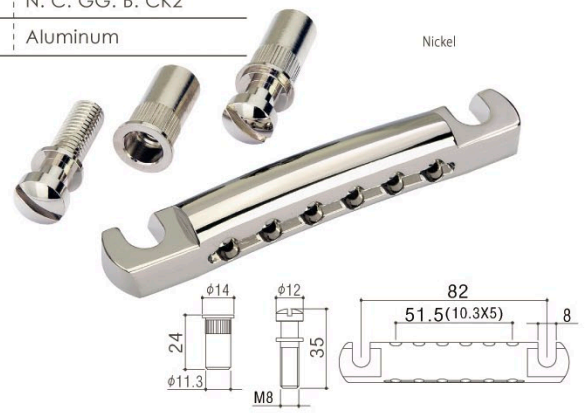

GE103B

Finishes | N. C. GG. B. CK2

Hard zinc saddle

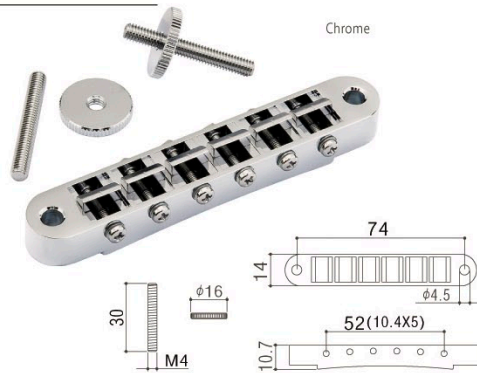

AS103B

Finishes | N. C. GG. B. CK2

Aluminum Bronze saddle

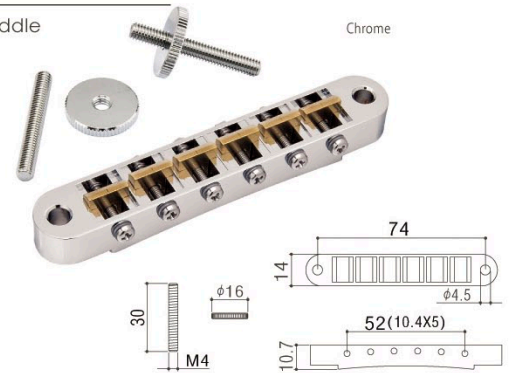

GE103B-T

Finishes | N. C. GG. B. CK2

Hard zinc saddle



AS103B-T

Finishes | N. C. GG. B. CK2

Aluminum Bronze saddle



GE104B

Finishes | N. C. GG. B. CK2

Hard zinc saddle

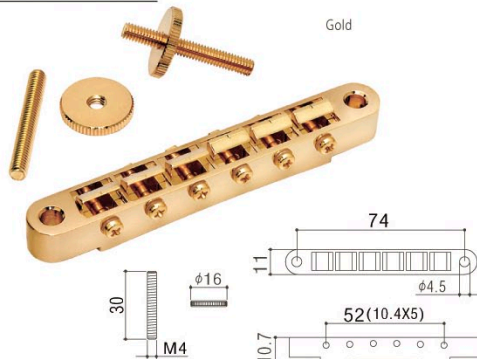

GEP104B

Finishes | N. C. GG. B. CK2

Plastic saddle

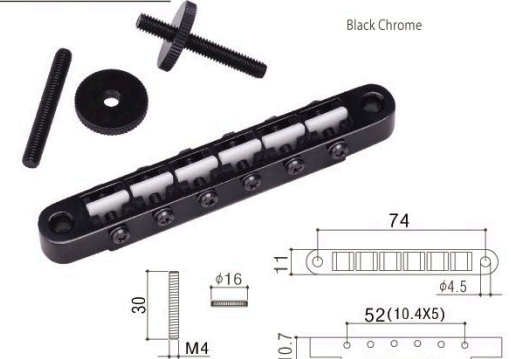

"Multi-Tonal" Series

Bass Bridges



303SJ

Finishes : C. GG. B. CK2. XN. XC. XG

Duralumin plate,
Steel saddle

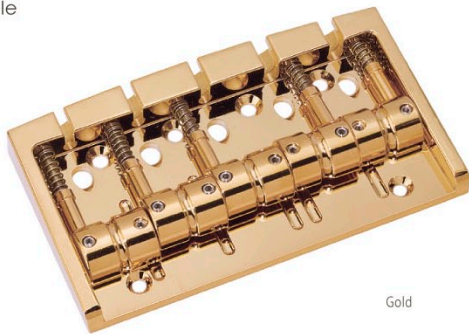

Gold

303SJ-4

String pitch 19mm

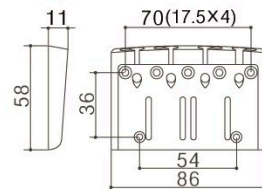

4-strings

303SJ-5

String pitch 18mm

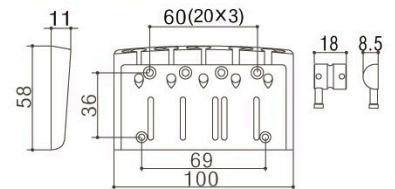

5-strings

303SJ-6

String pitch 18mm

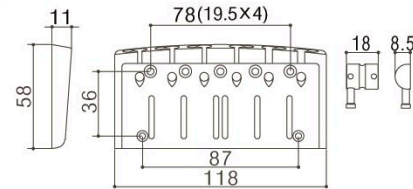

6-strings



303BO

Finishes : C. GG. B. CK2. XN. XC. XG

Duralumin plate,
Brass Saddle

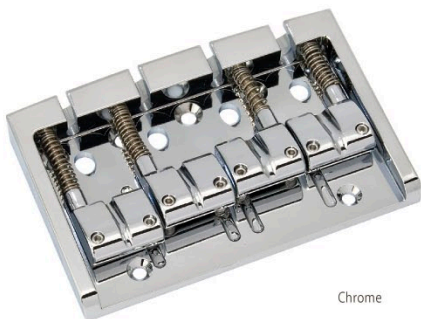

Chrome

303BO-4

String pitch 19mm

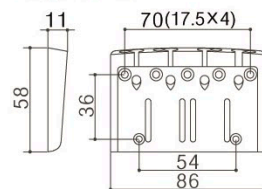

4-strings

303BO-5

String pitch 18mm

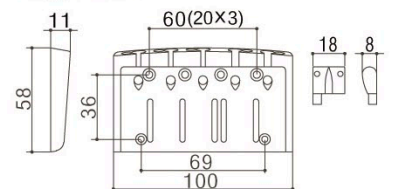

5-strings

303BO-6

String pitch 18mm

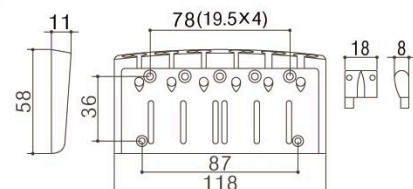

6-strings



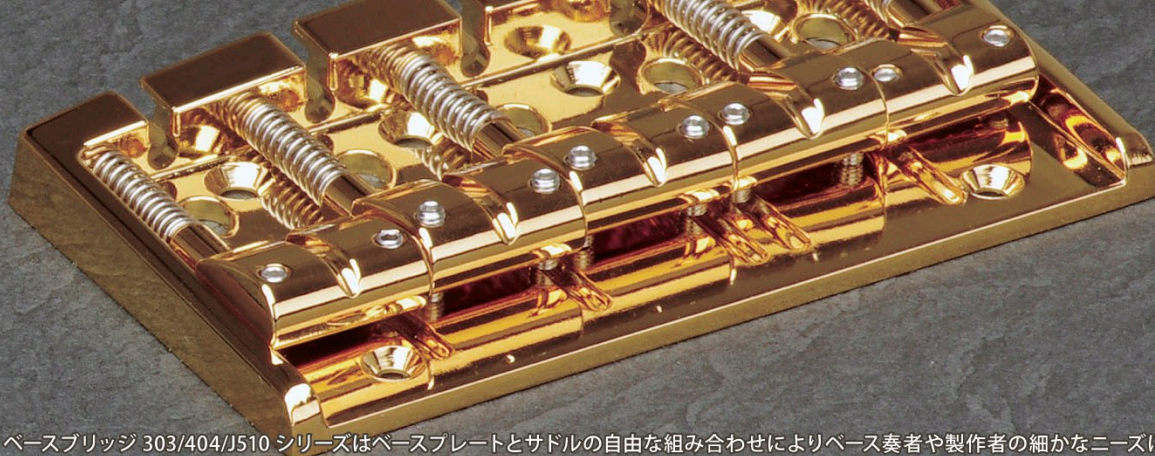

ベースブリッジ 303/404/J510 シリーズはベースプレートとサドルの自由な組み合わせによりベース奏者や製作者の細かなニーズに対応するシリーズです。303 モデルのベースプレートは、RES-O-LITE と呼ぶ特殊ジュラルミン材のプレートを使用しています。RES-O-LITE 特有の音響特性により、弦の振動をすばやくボディに伝える事ができます。404/J510 モデルのベースプレートは音色に定評のあるハードジンク材を使用し、より響きのあるサウンドを作ります。各シリーズでサドルを SJ (スチール)、BO (プラス) から選び、組み合わせる事により、今までにないユニークな音を創造できユーザー独自のブリッジを創ることができます。

404SJ

Finishes C. GG. B. CK2. XN. XC. XG

Hard zinc plate,
Steel saddle

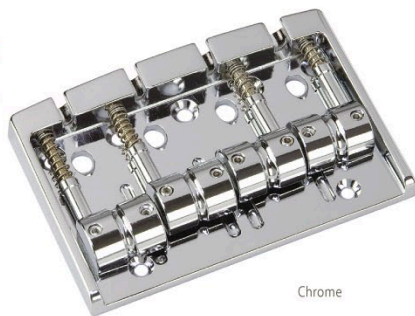

404SJ-4

String pitch 19mm

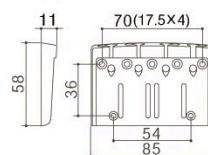

4-strings

404SJ-5

String pitch 18mm

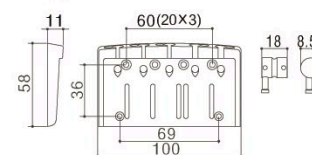

5-strings

404BO

Finishes C. GG. B. CK2. XN. XC. XG

Hard zinc plate,
Brass saddle

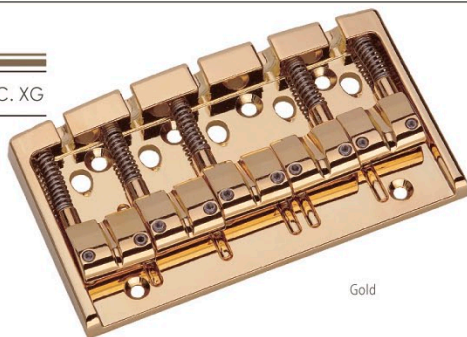

404BO-4

String pitch 19mm

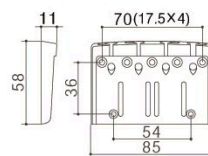

4-strings

404BO-5

String pitch 18mm

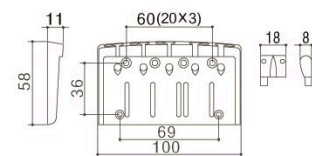

5-strings

J510SJ

Finishes C. GG. B. CK2. XN. XC. XG

Hard zinc plate,
Steel saddle

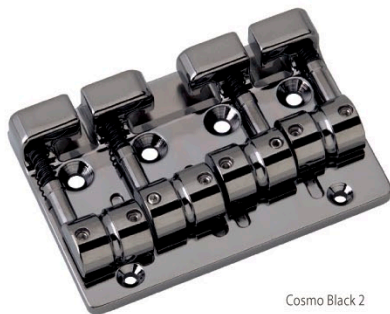

J510SJ-4

String pitch 19mm

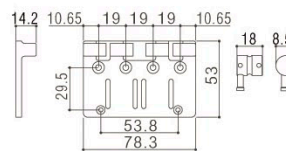

4-strings

J510SJ-5

String pitch 18mm

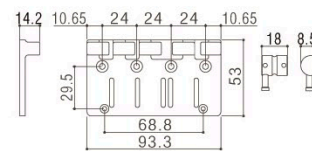

5-strings

J510BO

Finishes C. GG. B. CK2. XN. XC. XG

Hard zinc plate,
Brass saddle



J510BO-4

String pitch 19mm

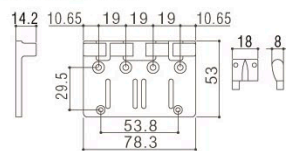

4-strings

J510BO-5

String pitch 18mm

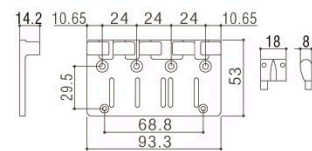

5-strings

S510B

Finishes C. GG. B. CK2

Brass saddle
Steel plate
String pitch : 19mm

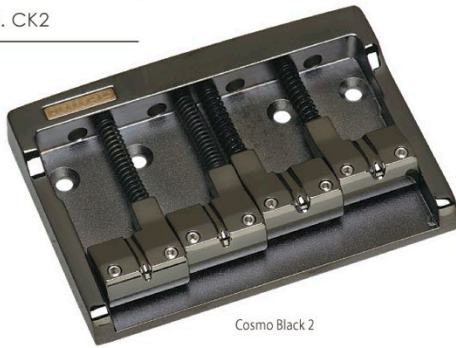

Cosmo Black 2

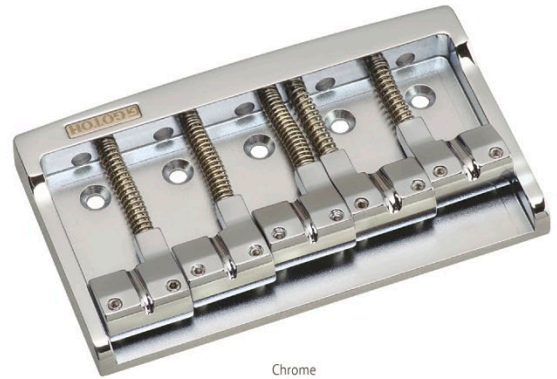

Chrome

S510B-4

4-strings

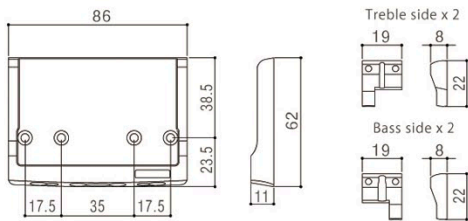

S510B-5

5-strings

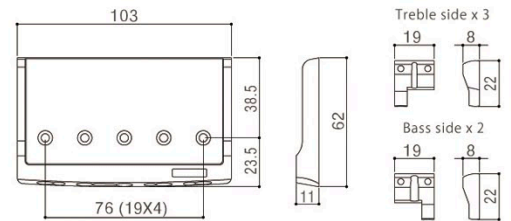

201B-4

Finishes C. GG. B. CK2

Brass saddle,
String pitch 19mm

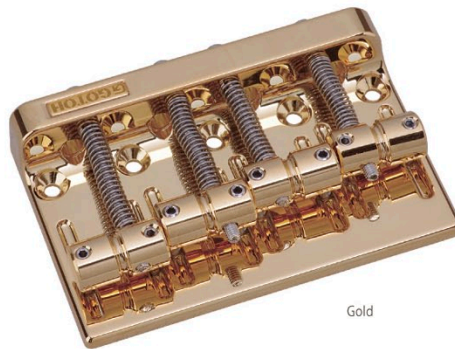

Gold

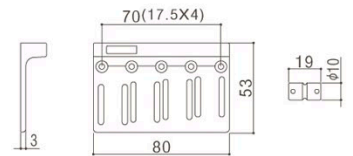

203B-4

Finishes N. C. GG. B. CK2

Brass Saddle,
String pitch 19mm

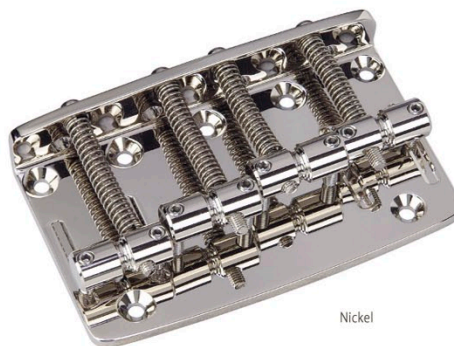

Nickel

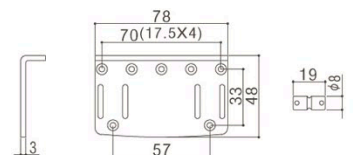

205B-5

Finishes N. C. GG. B. CK2

5-strings
Brass saddle,
string pitch 18mm

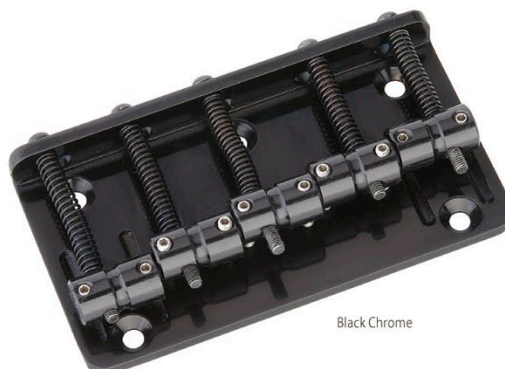

Black Chrome

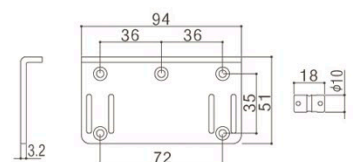

Art Collection

GOTOH「SUPREME GLYPTOGRAPHY - スプリーム・グリフトグラフィ」は超微細、超高速の機械(マシン)彫刻により、これまでにない芸術的装飾パーツを皆様に提供致します。この技術で、あなたの頭の中にだけあったイメージを現実世界に顕在させることが可能となりました。



GUITAR BRIDGE

GTC-Art-01

FINISHES : C. GG. B. CK2

BASS BRIDGE

203B-Art-01

FINISHES : N. C. GG. B. CK2

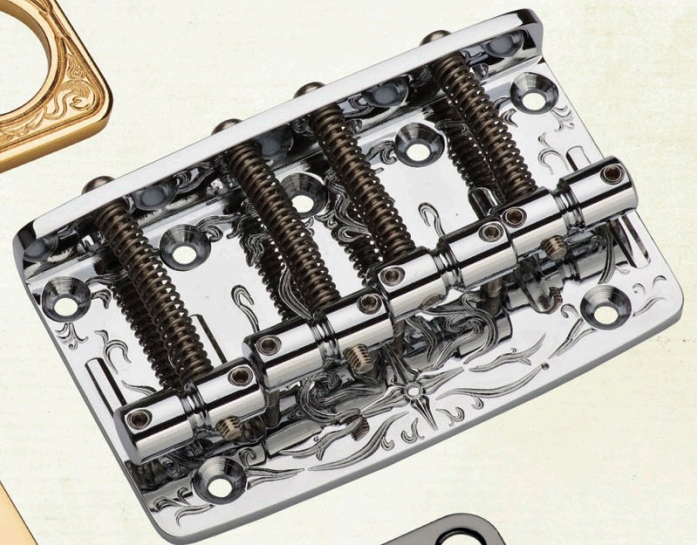

NECK JOINT PLATE

NBS-Art

FINISHES : C. GG. B. CK2



NBS-Art-01
(クレスト)



NBS-Art-02
(浮世絵)



NBS-Art-03
(イーグル)

CONTROL KNOB

VK-Art (VK1-19)

FINISHES : C. GG. B. CK2



VK-Art-01 (ホルスの眼)



VK-Art-02 (スカル)



VK-Art-03 (クロス)



Arms

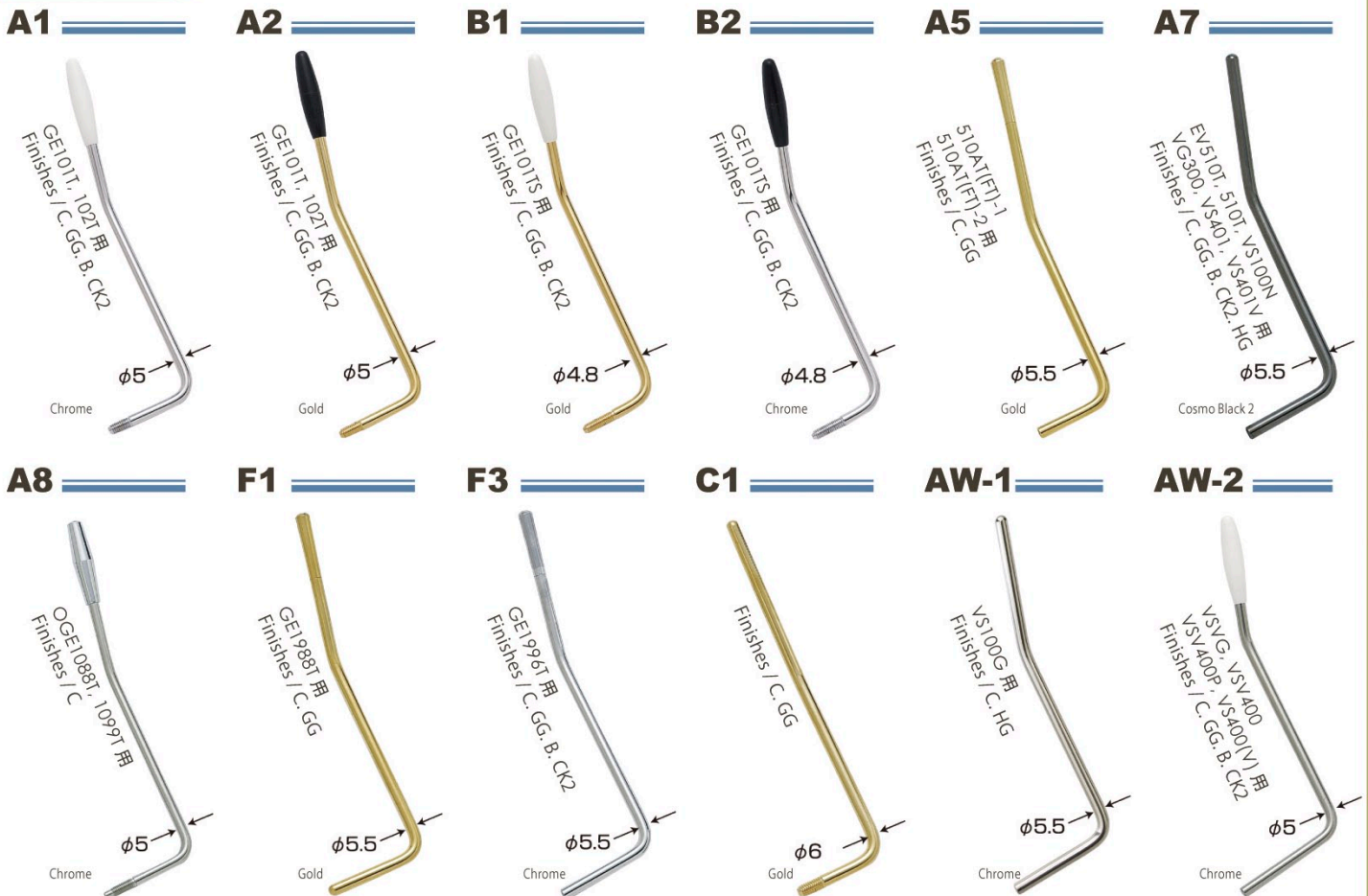

Finishes : C (Chrome), GG (Gold), B (Black Chrome), CK2 (Cosmo Black 2), HG (Honed Gold)

Saddle Sets

<p>S101</p> <p>Finishes N. GG. B. CK2</p> <p>Material Steel (sheet metal)</p> <p>6pcs/set</p>  <p>Nickel</p>	<p>S101S</p> <p>Finishes N. GG. B. CK2</p> <p>Material Steel (sheet metal) with USA threads screws</p> <p>6pcs/set</p>  <p>Gold</p>	<p>S102</p> <p>Finishes C. GG. B. CK2</p> <p>Material Steel</p> <p>6pcs/set</p>  <p>Cosmo Black 2</p>	<p>S108</p> <p>Finishes N. GG. B. CK2</p> <p>Material Steel (sheet metal)</p> <p>6pcs/set</p>  <p>Nickel</p>	<p>S188</p> <p>Finishes N. GG. B. CK2</p> <p>Material Steel (sheet metal)</p> <p>6pcs/set</p>  <p>Nickel</p>
<p>S199</p> <p>Finishes C. GG. B. CK2</p> <p>Material Steel</p> <p>6pcs/set</p>  <p>Gold</p>	<p>S11</p> <p>Finishes C. GG. B. CK2</p> <p>Material Brass</p> <p>6pcs/set</p>  <p>Gold</p>	<p>S21</p> <p>Finishes C. GG. B. CK2</p> <p>Material Steel</p> <p>6pcs/set</p>  <p>Chrome</p>	<p>S12</p> <p>Finishes C. GG. B. CK2</p> <p>Material Brass</p> <p>6pcs/set</p>  <p>Cosmo Black 2</p>	<p>S22</p> <p>Finishes C. GG. B. CK2</p> <p>Material Steel</p> <p>6pcs/set</p>  <p>Gold</p>
<p>SW-3</p> <p>Finish SB</p> <p>Material Brass</p> <p>3pcs/set</p> 	<p>S201</p> <p>Finishes C. GG. B. CK2</p> <p>Material Brass</p> <p>4pcs/set</p>  <p>Chrome</p>	<p>S203</p> <p>Finishes N. C. GG. B. CK2</p> <p>Material Brass</p> <p>4pcs/set</p>  <p>Gold</p>	<p>S205</p> <p>Finishes N. C. GG. B. CK2</p> <p>Material Brass</p> <p>5pcs/set</p>  <p>Cosmo Black 2</p>	

Side Adjuster PAT.P

GOTOH Side Adjuster は、6 角レンチにてネックエンド側面からネック反りを調整する理想的なアジャストシステムです。従来のようにボディからネックを外したり、弦と弦の間の作業性の悪い場所でトラスロッドを調整する必要はありません。各弦を少しゆるめるだけで簡単にネック調整ができます。

※既存のネックに後から組み込むことはできません。

SAT-1

ワンピースネック用

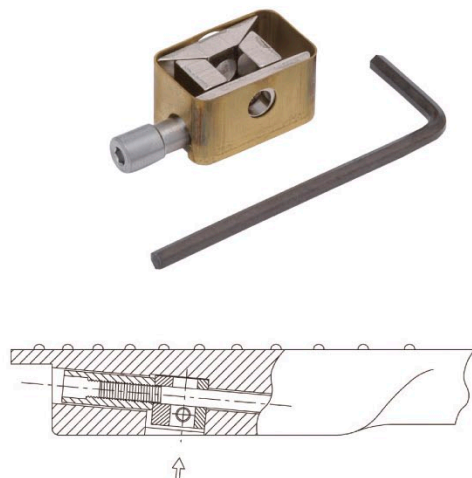

SAT-2

指板貼ネック用

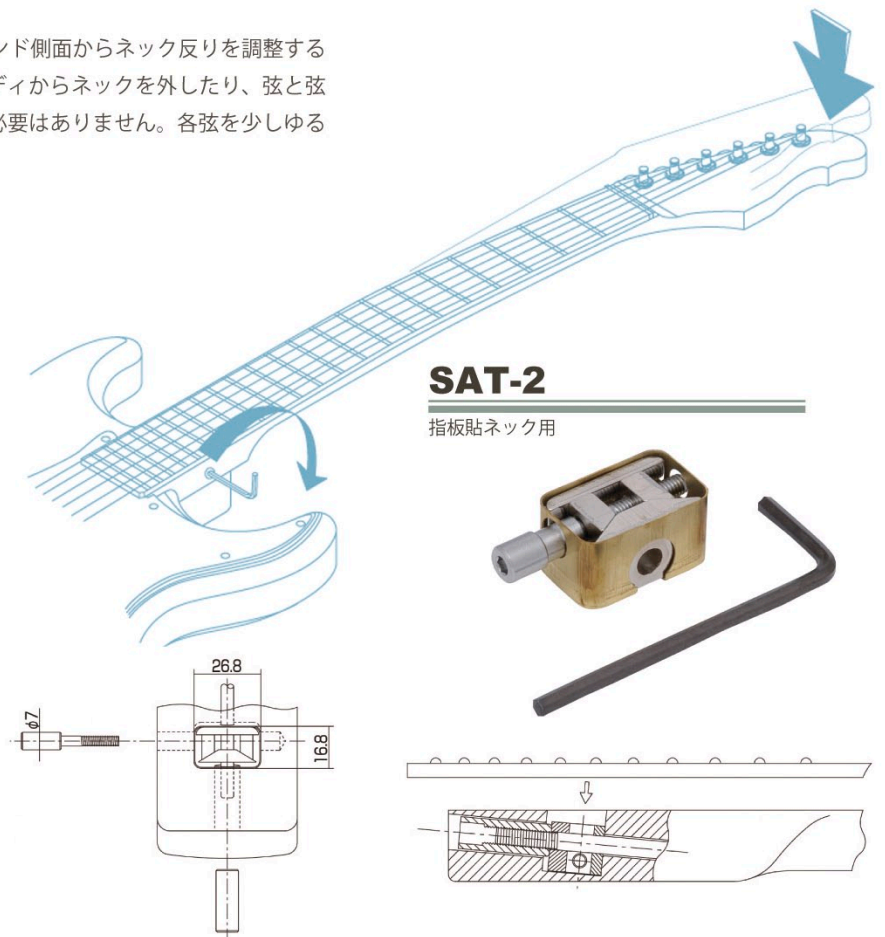

Strap Pin

EP-A1

Aluminum

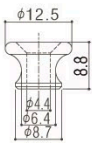

EP-B1

Finishes | N. C. GG. B. CK2

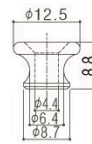

Gold

EP-B2

Finishes | N. C. GG. B. CK2

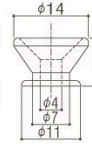

Cosmo Black 2

EP-B3

Finishes | N. C. GG. B. CK2

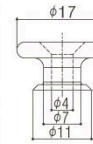

Nickel

EP-FR2

Finishes | C. GG. B. CK2

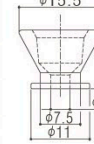

Chrome

Free Lock

EPR-2

Finishes | C. GG. B. CK2

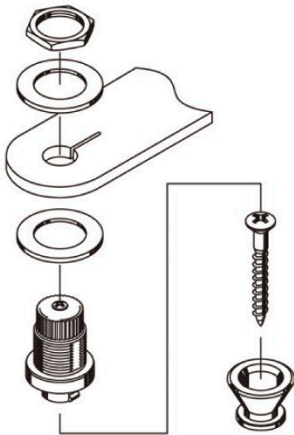

Gold

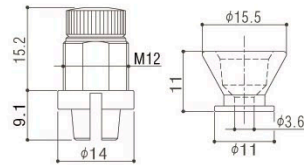

String Bushing

TLB-1

Finishes | N. C. GG. B. CK2



Nickel

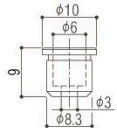

TLB-2

Finishes | N. C. GG. B. CK2



Cosmo Black 2

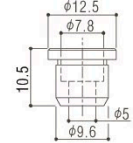

Jack Cover

JCS-1

Finishes | C. GG. B. CK2



Cosmo Black 2

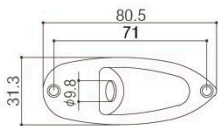

JCB-2

Finishes | C. GG. B. CK2



Chrome

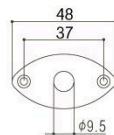

JCB-4

Finishes | C. GG. B. CK2



Gold

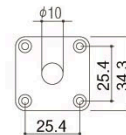

Neck Joint Plate

NBS-3

Finishes | C. GG. B. CK2



Chrome

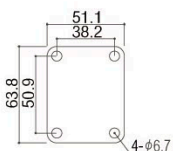

Strap Pin

EP-A1

Aluminum

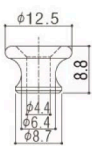

EP-B1

Finishes | N. C. GG. B. CK2

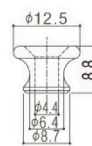

Gold

EP-B2

Finishes | N. C. GG. B. CK2

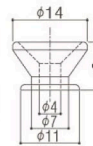

Cosmo Black 2

EP-B3

Finishes | N. C. GG. B. CK2

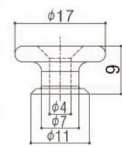

Nickel

EP-FR2

Finishes | C. GG. B. CK2

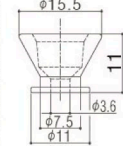

Chrome

Free Lock

EPR-2

Finishes | C. GG. B. CK2

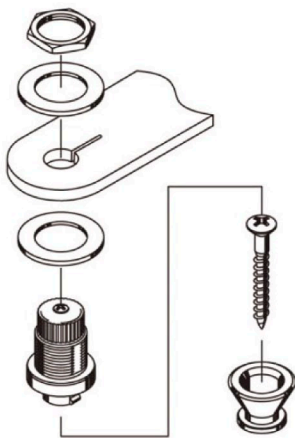

Gold

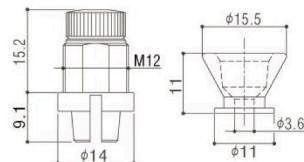

String Bushing

TLB-1

Finishes | N. C. GG. B. CK2



Nickel

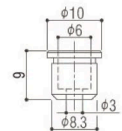

TLB-2

Finishes | N. C. GG. B. CK2



Cosmo Black 2

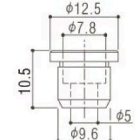

Jack Cover

JCS-1

Finishes | C. GG. B. CK2



Cosmo Black 2

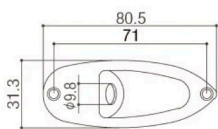

JCB-2

Finishes | C. GG. B. CK2



Chrome



JCB-4

Finishes | C. GG. B. CK2



Gold

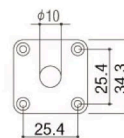

Neck Joint Plate

NBS-3

Finishes | C. GG. B. CK2



Chrome

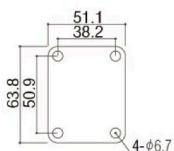

Battery Box

BB-02

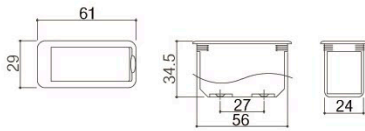

BB-04

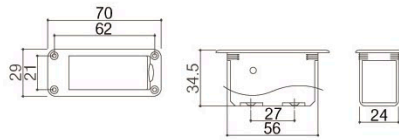

BB-04W

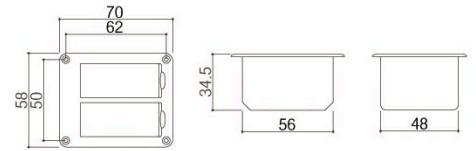

Wrench Holder

WRH-1W

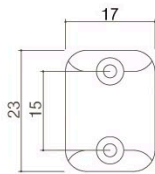

WRH-1

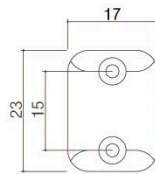

Spring Holder

SPH

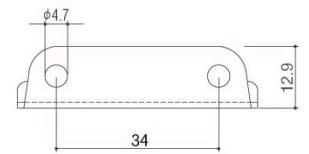

Power Spring

PSP

本来トレモロは、弦の張力とブロックに掛けられたコイルスプリングとのバランスで中立を保ちます。特にアームダウンをした後の原点復帰はコイルスプリングの力だけに依存される為、スプリングの精度が不安定な場合チューニングは正確に復元されません。パワースプリングは、強力な復元力でトレモロ操作で生じるチューニングの狂いを最小限に抑えることができます。



Spring

SP



Wilkinson®

Tremolo & Bridge

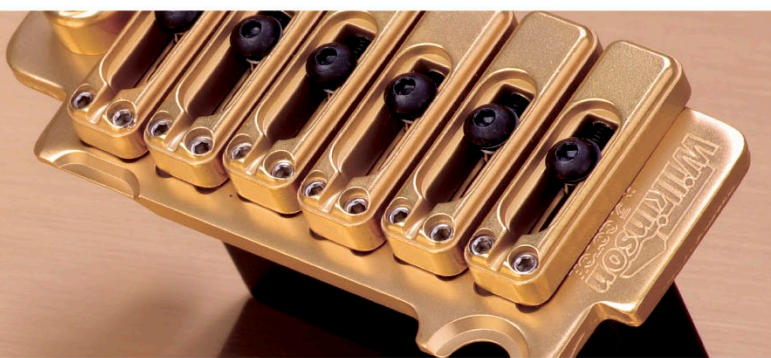

VS100N

Finishes HC. HG. HB. HCK2

String pitch 10.8mm
Stud lock-Pat.



Honed Gold

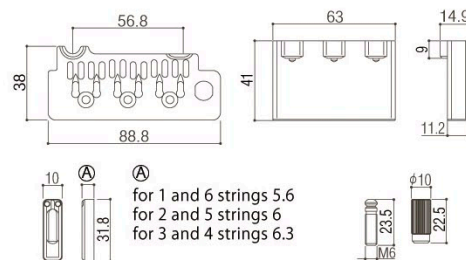

VG300

Finishes C. GG. B. CK2

String pitch 10.8mm
Stud lock-Pat.



Chrome

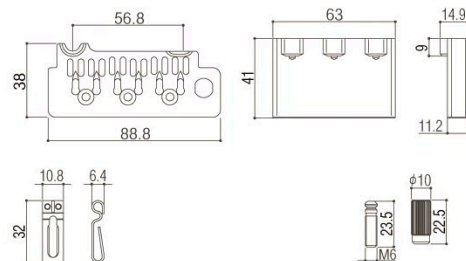

VSVG

Finishes N. GG. B. CK2

String pitch 10.8mm



Gold

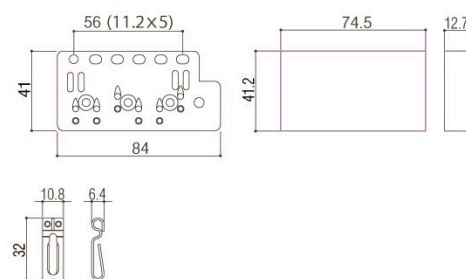

WT3

Finishes N. C. GG (Plate only)

String pitch 10.8mm



Nickel

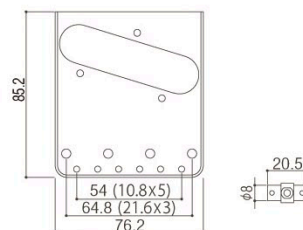

Parts Collection 2012 - 2013



www.g-gotoh.com

GOTOH[®]

〒372-0801 群馬県伊勢崎市宮子町 3040 TEL 0270-25-3608 FAX 0270-23-8432

■カタログ記載の内容は品質改善のため予告なく変更することがあります。 ■カタログに印刷された商品の色調は、実際の色と多少異なる場合がございます。 ■このカタログの内容は2011年11月現在のものです。
© 無断でカタログの内容の全体、または一部の複写・複製全てを禁じます。